



More Precision

wireSENSOR // Draw-wire displacement sensors



Draw-wire sensors

wireSENSOR

Measuring ranges up to 50,000 mm

Resolution towards infinity

Compact design with large measuring range

Easy, fast and flexible mounting

High operational safety & long service life

Analog and digital outputs



Measuring principle

Draw-wire displacement sensors measure linear movements using a highly flexible steel wire. The cable drum is attached to a sensor element which provides a displacement-proportional output signal. Measurements are performed with high accuracy and dynamics. High quality components ensure a long service life and high operational reliability.

Micro-Epsilon offers numerous models of different draw-wire displacement sensors with different output signal types. Therefore, you can choose the ideal sensor for your application. For special applications involving large numbers of pieces, we develop and manufacture individual OEM designs.

wireSENSOR models stand out due to their optimized ratio between measuring range and size, easy installation and handling. Their robust sensor design enables reliable measurements even in challenging ambient conditions.

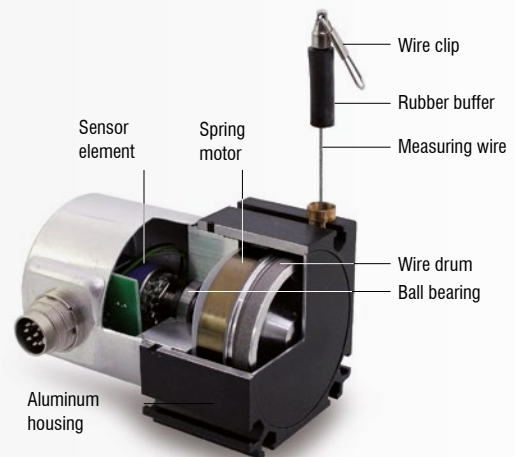











Sensor structure of a WDS-P60



Available measuring ranges per sensor group

Measuring ranges in mm	40	50	80	100	130	150	250	300	500	750	1000	1250	1500	2000	2100	2300	2400	2500	3000	3500	4000	5000	7500	8000	10000	15000	30000	40000	50000	
Draw-wire sensors for serial integration & OEM		■				■	■		■	■	■	■	■	■	■	■	■	■	■	■	■	■	■	■	■					
Industrial draw-wire sensors				■	■	■	■	■	■																	■	■	■	■	■
Sensors for high wire accelerations	■	■	■	■	■	■	■	■	■		■																			

Available outputs per series and measuring range

Draw-wire sensors for serial integration & OEM																			Page			
Measuring ranges in mm			50	150	250	500	750	1000	1250	1500	2100	2300	2400	2500	3000	3500	5000	7500	8000			
	MK30	analog	P	P	P	P	P														6 - 7	
		digital				E	E															8 - 9
	MK46	analog						P	PU I												10 - 11	
		digital							E													12 - 13
	MK77	analog									P										14 - 15	
		digital									E											16 - 17
	MK60	analog									PU I										18 - 19	
		digital											E									20 - 21
	MK88	analog											PU I				PU I	PU I			22 - 23	
		digital											P				P	P				24 - 25
	MK120	analog															PU I		PU I	PU I	26 - 27	
		digital																				
	K100	analog									PU I			PU I			PU I	PU I			PU I	28 - 29
		digital										PC			PC		PC	PC			PC	30 - 31

Industrial draw-wire sensors																			Page					
Measuring ranges in mm			100	150	300	500	750	1000	1500	2000	2500	3000	4000	5000	7500	10000	15000	30000	40000	50000				
	P60	analog	PU I	PU I	PU I	PU I	PU I	PU I	PU I													32 - 33		
		digital						E A	E A														34 - 35	
	P96	analog								PU I	PU I											36 - 37		
		digital										E A											38 - 39	
	P115	analog										PU I	PU I	PU I	PU I	PU I	PU I					40 - 41		
		digital												E A	E A	E A	E A					42 - 43		
	P200	analog																			E A	E A	E A	44 - 45

Sensors for high wire accelerations												Page		
Measuring ranges in mm			40	50	80	100	130	150	250	300	500	1000		
	MT	analog	P			P		P						46 - 47
		analog		P					P	P				48 - 49
	MP/ MPW	analog				P				P	P		P	50 - 51

P Potentiometer U Voltage I Current E Incremental encoder (HTL, TTL) A Absolute-encoder (SSI, PROFINET, PROFIBUS, CANopen, EtherCAT, EtherNet/IP) C CANopen

Applications

wireSENSOR



Mobile machines: booms, supports & telescopic loaders



Measurement of the extension length of telescopic booms



Variable support for mobile cranes



Measuring the lift height in telescopic loaders



Lift tables: lifting platform, scissors lift tables



Measuring the lift height in synchronous lifting systems



Measuring the lift height in scissors lift tables



Industrial vehicles & driverless transport systems



Measuring the lift height in forklift trucks



Measuring the lift height in driverless transport systems



Medical technology: operating tables & mammography



Position measurement in Computer Tomography (CT)



Positioning of operating tables



Position measurement in mammography



Test bench construction and road tests: chassis test benches & crash tests



Spring travel measurement in road tests

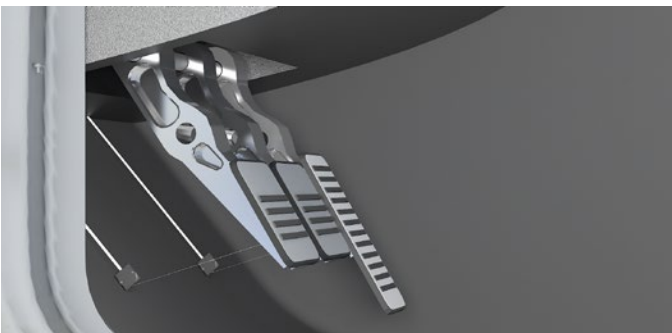

Measuring the pedal travel



Displacement measurement in crash tests

Low-cost draw-wire sensors wireSENSOR MK30 analog

Robust plastic housing

Customer-specific designs

Conductive plastic/wire/hybrid potentiometer

Smallest design in its class



Measuring range 50 mm

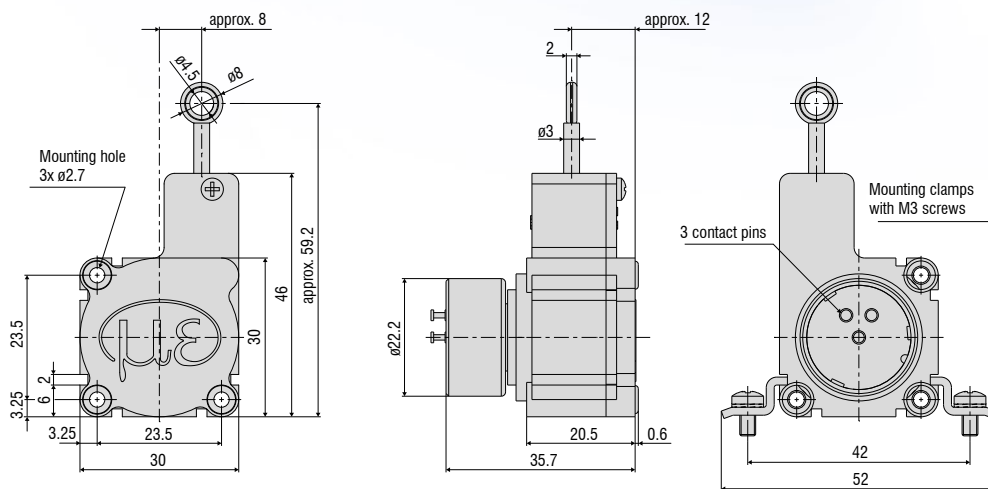

Measuring range 150/250/500/750 mm

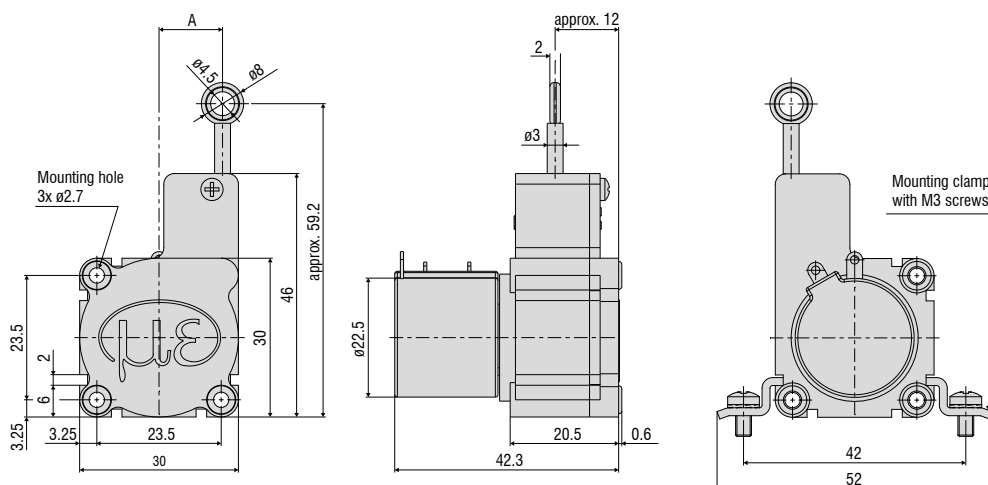

Measuring range (mm)	A (mm)
150 / 250 / 500	approx. 8
750	approx. 12

All dimensions in mm, not to scale

Model		WPS-50-MK30	WPS-150-MK30	WPS-250-MK30	WPS-500-MK30	WPS-750-MK30
Measuring range		50 mm	150 mm	250 mm	500 mm	750 mm
Analog output ¹⁾		Potentiometer				
Resolution	Conductive plastic potentiometer	towards infinity	-	-	-	-
	Wire potentiometer	-	-	-	0.15 mm	0.2 mm
	Hybrid potentiometer	-	towards infinity			
Linearity	Conductive plastic potentiometer P50	≤ ±0.5% FSO	≤ ±0.25 mm	-	-	-
	Wire potentiometer P25	≤ ±0.25% FSO	-	-	≤ ±1.25 mm	≤ ±1.87 mm
	Hybrid potentiometer P25	≤ ±0.25% FSO	-	≤ ±0.375 mm	≤ ±0.625 mm	-
	Hybrid potentiometer P10	≤ ±0.1% FSO	-	-	≤ ±0.25 mm	≤ ±0.5 mm
Sensor element		Conductive plastic potentiometer	Hybrid potentiometer		Wire/hybrid potentiometer	
Wire extension force (max.)		approx. 2.5 N				
Wire retraction force (min.)		approx. 1 N				
Wire acceleration (max.)		approx. 5 g				
Material	Housing	Plastics				
	Measuring wire	Polyamide-coated stainless steel (ø 0.36 mm)				
Wire mounting		Eyelet (ø 4.5 mm)				
Installation		Mounting holes or mounting grooves on the sensor housing				
Temperature range	Storage	-20 ... +80 °C				
	Operation	-20 ... +80 °C				
Connection		Soldering tags				
Shock (DIN EN 60068-2-27)		50 g / 5 ms in 3 axes, 2 directions and 1000 shocks each				
Vibration (DIN EN 60068-2-6)		20 g / 20 ... 2000 Hz in 3 axes and 10 cycles each				
Protection class (DIN EN 60529)		IP20				
Weight		approx. 45 g				

FSO = Full Scale Output

¹⁾ Specifications for analog outputs from page 58 onwards.

Article designation

WPS -	50 -	MK30 -	P25
			Output type: Potentiometer P50 (linearity ±0.5 % FSO) Potentiometer P25 (linearity ±0.25 % FSO) Potentiometer P10 (linearity ±0.1 % FSO)
			MK30 series
			Measuring range in mm

Low-cost draw-wire sensors wireSENSOR MK30 digital

Robust plastic housing

Customer-specific designs

Incremental encoder

Smallest design in its class

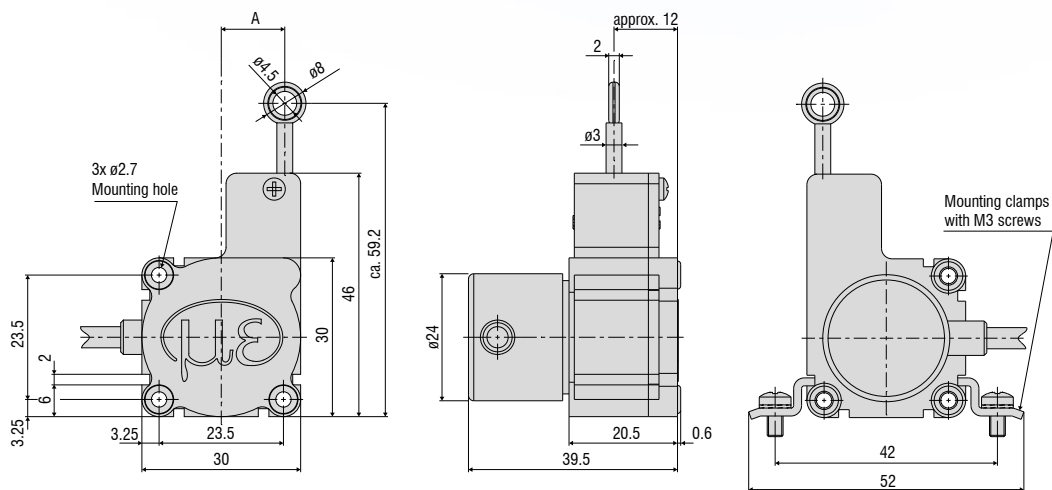

Measuring range (mm)	A (mm)
500	approx. 8
750	approx. 12

All dimensions in mm, not to scale

Model	WPS-500-MK30	WPS-750-MK30
Measuring range	500 mm	750 mm
Digital output ¹⁾	Encoder: E (5 ... 24 VDC) / Encoder E830 (8 ... 30 VDC)	
Resolution	10 pulses/mm	6.7 pulses/mm
	0.1 mm	0.15 mm
Linearity	≤ ±0.05% FSO	≤ ±0.375 mm
Sensor element	Incremental encoder	
Wire extension force (max.)	approx. 2.5 N	
Wire retraction force (min.)	approx. 1 N	
Wire acceleration (max.)	approx. 5 g	
Material	Housing	Plastics
	Measuring wire	Polyamide-coated stainless steel (ø 0.36 mm)
Wire mounting	Eyelet (ø 4.5 mm)	
Installation	Mounting holes or mounting grooves on the sensor housing	
Temperature range	Storage	-20 ... +80 °C
	Operation	-20 ... +80 °C
Connection	integrated cable, radial, length 1 m	
Shock (DIN EN 60068-2-27)	50 g / 5 ms in 3 axes, 2 directions and 1000 shocks each	
Vibration (DIN EN 60068-2-6)	20 g / 20 ... 2000 Hz in 3 axes and 10 cycles each	
Protection class (DIN EN 60529)	IP54	
Weight	approx. 80 g (incl. cable)	

FSO = Full Scale Output

¹⁾ Specifications for digital outputs from page 59 onwards.

Article designation

WPS -	500 -	MK30 -	E830
			Output type: Encoder E (5 ... 24 VDC) Encoder E830 (8 ... 30 VDC)
			MK30 series
			Measuring range in mm

Low-cost draw-wire sensors wire**SENSOR** MK46 analog

Robust plastic housing

Customer-specific designs

Wire or hybrid potentiometer



Output P10/P25

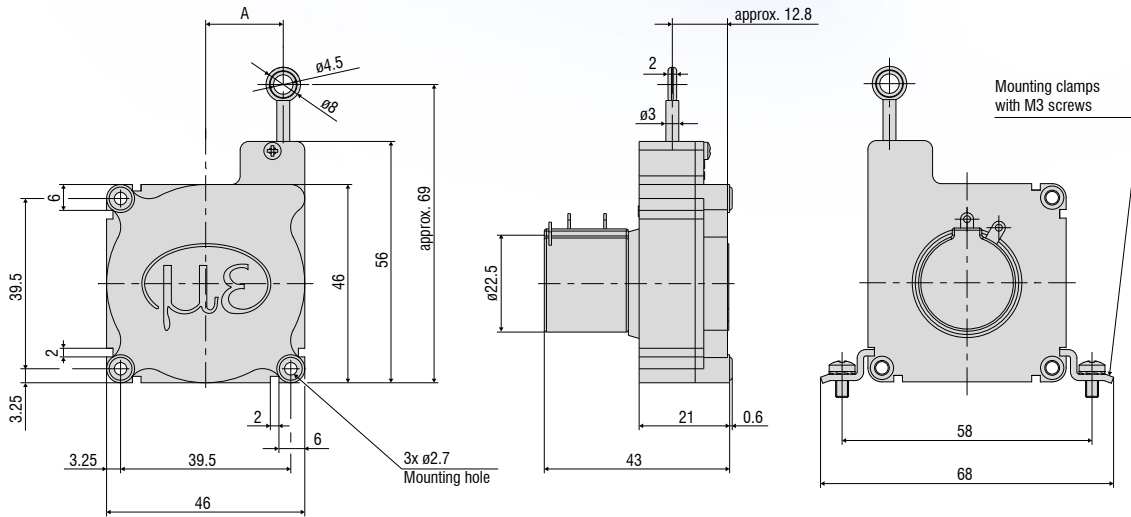

Measuring range (mm)	A (mm)
1000	approx. 18
1250	approx. 20

Output CR-P10/CR-P25/CR-U10/CR-I10

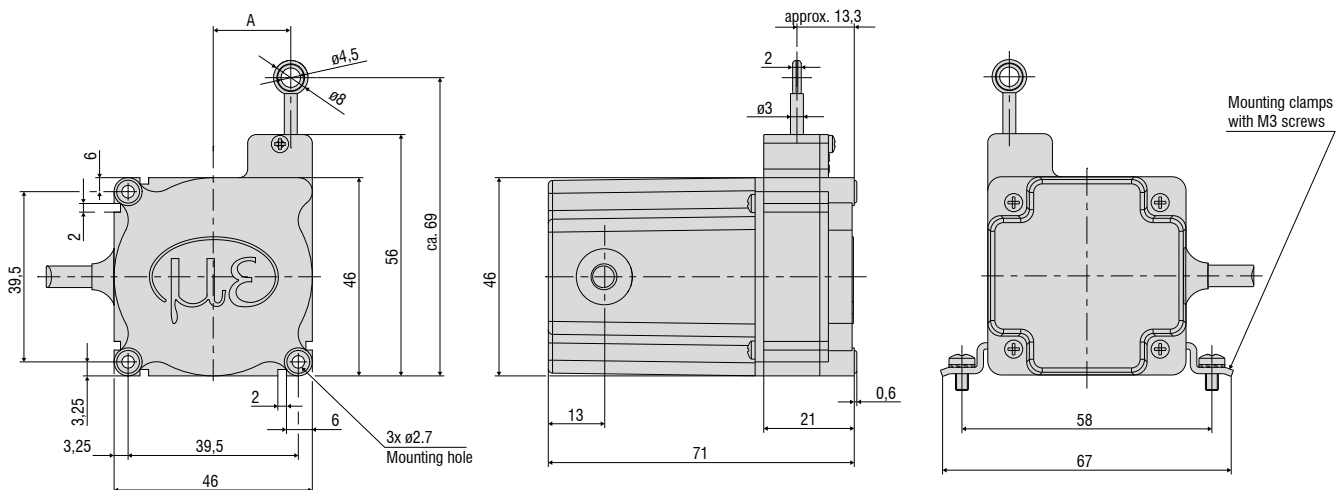

All dimensions in mm, not to scale

Model		WPS-1000-MK46	WPS-1250-MK46
Measuring range		1000 mm	1250 mm
Analog output		Potentiometer	Potentiometer, current, voltage
Resolution	Wire potentiometer P25	0.3 mm	0.4 mm
	Hybrid potentiometer P10/U10/I10	towards infinity	
Linearity	Wire potentiometer P25 $\leq \pm 0.25\%$ FSO	$\leq \pm 2.5$ mm	$\leq \pm 3.12$ mm
	Hybrid potentiometer P10/U10/I10 $\leq \pm 0.1\%$ FSO	$\leq \pm 1$ mm	$\leq \pm 1.2$ mm
Sensor element		Wire/hybrid potentiometer	
Wire extension force (max.)		approx. 1.6 N	approx. 1.5 N
Wire retraction force (min.)		approx. 1 N	
Wire acceleration (max.)		approx. 5 g	
Material	Housing	Plastics	
	Measuring wire	Polyamide-coated stainless steel (\varnothing 0.36 mm)	
Wire mounting		Eyelet (\varnothing 4.5 mm)	
Installation		Mounting holes or mounting grooves on the sensor housing	
Temperature range	Storage	-20 ... +80 °C	
	Operation	-20 ... +80 °C	
Connection	P10/P25	Soldering tags	
	CR-P10/CR-P25/CR-U10/CR-I10	integrated cable, radial, length 1 m	
Shock (DIN EN 60068-2-27)		50 g / 5 ms in 3 axes, 2 directions and 1000 shocks each	
Vibration (DIN EN 60068-2-6)		20 g / 20 ... 2000 Hz in 3 axes and 10 cycles each	
Protection class (DIN EN 60529)		IP20	
Weight		approx. 80 g	

FSO = Full Scale Output

¹⁾ Specifications for analog outputs from page 58 onwards.

Article designation

WPS -	1000 -	MK46 -	P25
			Output type: P10: Potentiometer P25: Potentiometer CR-P10/P25: potentiometer, integrated cable, radial, 1 m
			MK46 series
			Measuring range in mm

WPS -	1250 -	MK46 -	P25
			Output type: P10: Potentiometer P25: Potentiometer CR-P10/P25: potentiometer, integrated cable, radial, 1 m CR-U10: Voltage, integrated cable, radial, 1 m CR-I10: Current, integrated cable, radial, 1 m
			MK46 series
			Measuring range in mm

Low-cost draw-wire sensors wire**SENSOR** MK46 digital

Robust plastic housing

Customer-specific designs

Incremental encoder

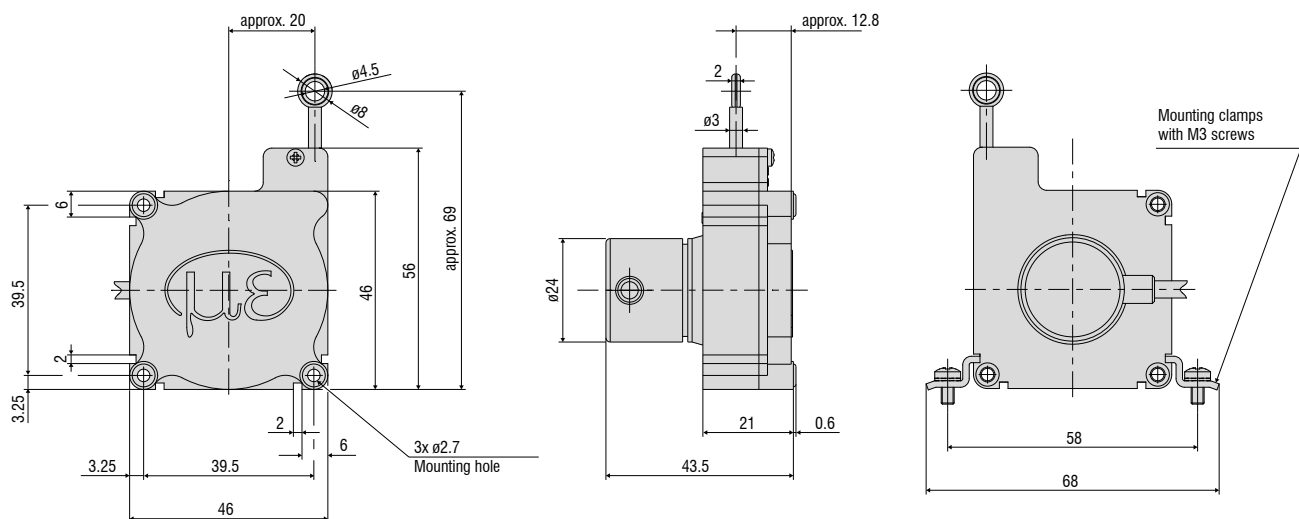

All dimensions in mm, not to scale

Model		WPS-1250-MK46
Measuring range		1250 mm
Digital output ¹⁾		Encoder: E (5 ... 24 VDC) / Encoder E830 (8 ... 30 VDC)
Resolution		4 pulses/mm
		0.25 mm
Linearity	≤ ±0.05% FSO	≤ ±0.625 mm
Sensor element		Incremental encoder
Wire extension force (max.)		approx. 1.5 N
Wire retraction force (min.)		approx. 1 N
Wire acceleration (max.)		approx. 5 g
Material	Housing	Plastics
	Measuring wire	Polyamide-coated stainless steel (ø 0.36 mm)
Wire mounting		Eyelet (ø 4.5 mm)
Installation		Mounting holes or mounting grooves on the sensor housing
Temperature range	Storage	-20 ... +80 °C
	Operation	-20 ... +80 °C
Connection		integrated cable, radial, length 1 m
Shock (DIN EN 60068-2-27)		50 g / 5 ms in 3 axes, 2 directions and 1000 shocks each
Vibration (DIN EN 60068-2-6)		20 g / 20 ... 2000 Hz in 3 axes and 10 cycles each
Protection class (DIN EN 60529)		IP54
Weight		approx. 120 g (incl. cable)

FSO = Full Scale Output

¹⁾ Specifications for digital outputs from page 59 onwards.

Article designation

WPS -	1250 -	MK46 -	E
			Output type: Encoder E (5 ... 24 VDC) Encoder E830 (8 ... 30 VDC)
			MK46 series
			Measuring range in mm

Low-cost draw-wire sensors wire**SENSOR** MK77 analog

Robust plastic housing

Customer-specific designs

Wire potentiometer



Output P25

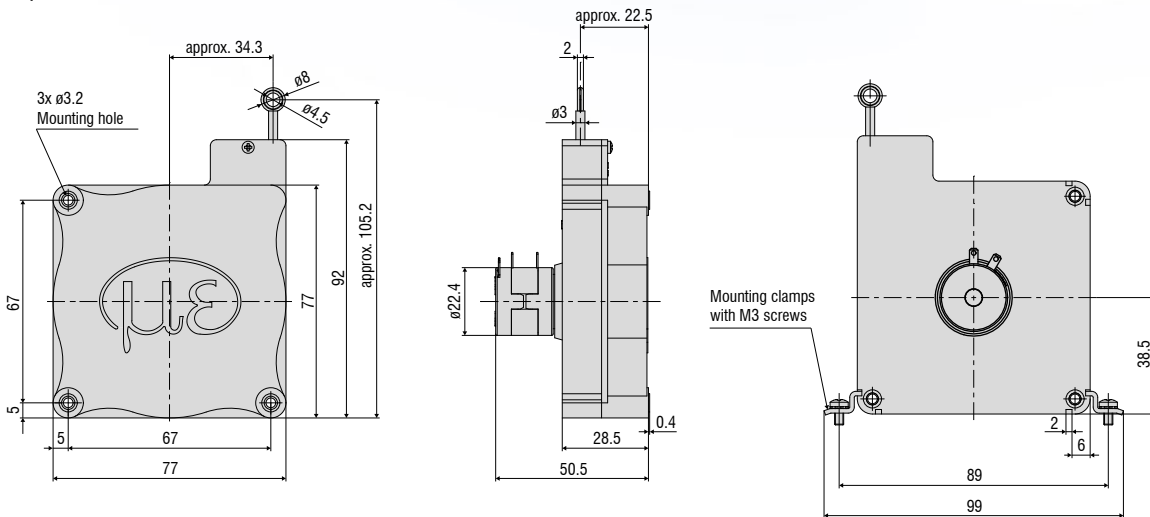

Output CR-P25

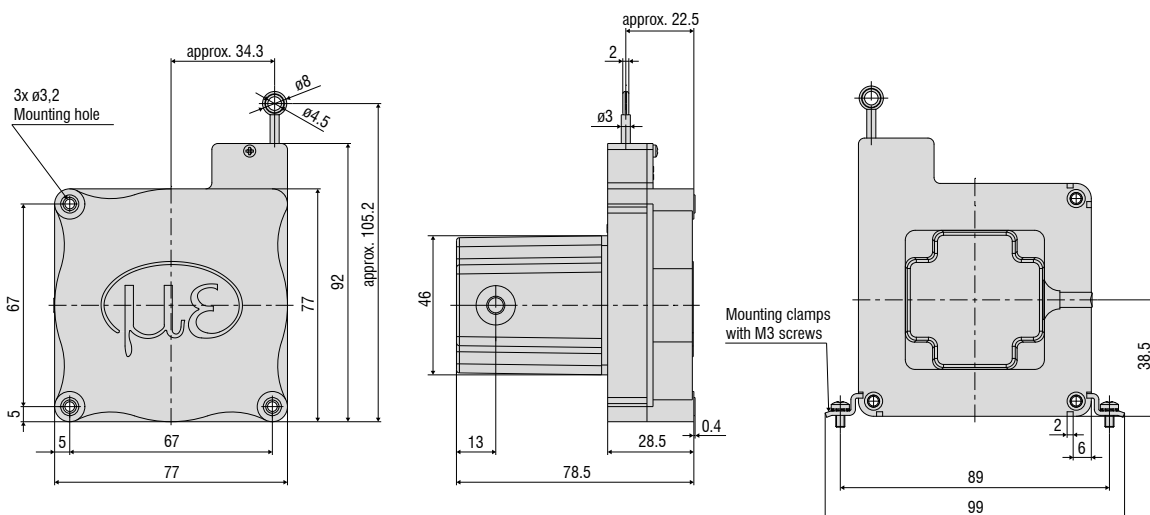

All dimensions in mm, not to scale

Model		WPS-2100-MK77
Measuring range		2100 mm
Analog output		Potentiometer
Resolution	Wire potentiometer P25	0.55 mm
Linearity	Wire potentiometer P25 $\leq \pm 0.25\%$ FSO	$\leq \pm 5.25$ mm
Sensor element		Wire potentiometer
Wire extension force (max.)		approx. 5 N
Wire retraction force (min.)		approx. 3.5 N
Wire acceleration (max.)		approx. 5 g
Material	Housing	Plastics
	Measuring wire	Polyamide-coated stainless steel (\varnothing 0.45 mm)
Wire mounting		Eyelet (\varnothing 4.5 mm)
Installation		Mounting holes or mounting grooves on the sensor housing
Temperature range	Storage	-20 ... +80 °C
	Operation	-20 ... +80 °C
Connection	P25	Soldering tags
	CR-P25	integrated cable, radial, length 1 m
Shock (DIN EN 60068-2-27)		50 g / 5 ms in 3 axes, 2 directions and 1000 shocks each
Vibration (DIN EN 60068-2-6)		20 g / 20 ... 2000 Hz in 3 axes and 10 cycles each
Protection class (DIN EN 60529)		IP20
Weight	P25	approx. 220 g
	CR-P25	approx. 275 g (incl. cable)

FSO = Full Scale Output

Specifications for analog outputs from page 58 onwards.

Article designation

WPS - 2100 - MK77 - P25

Output type:
Potentiometer P25 (linearity $\pm 0.25\%$ FSO)
CR-P25 potentiometer, integrated cable, radial, 1 m

MK77 series

Measuring range in mm

Low-cost draw-wire sensors
wireSENSOR MK77 digital

Robust plastic housing

Customer-specific designs

Incremental encoder

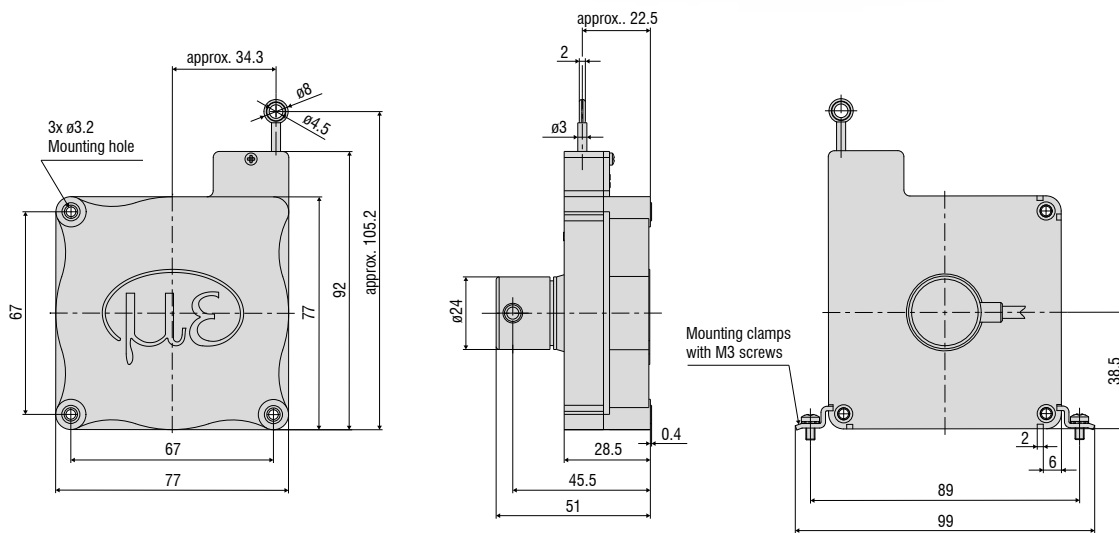

All dimensions in mm, not to scale

Model		WPS-2100-MK77
Measuring range		2100 mm
Digital output ¹⁾		Encoder: E (5 ... 24 VDC) / Encoder E830 (8 ... 30 VDC)
Resolution		2.32 pulses/mm
		0.43 mm
Linearity	≤ ±0.05% FSO	≤ ±1.05 mm
Sensor element		Incremental encoder
Wire extension force (max.)		approx. 5 N
Wire retraction force (min.)		approx. 3.5 N
Wire acceleration (max.)		approx. 5 g
Material	Housing	Plastics
	Measuring wire	Polyamide-coated stainless steel (ø 0.45 mm)
Wire mounting		Eyelet (ø 4.5 mm)
Installation		Mounting holes or mounting grooves on the sensor housing
Temperature range	Storage	-20 ... +80 °C
	Operation	-20 ... +80 °C
Connection		integrated cable, radial, length 2 m
Shock (DIN EN 60068-2-27)		50 g / 5 ms in 3 axes, 2 directions and 1000 shocks each
Vibration (DIN EN 60068-2-6)		20 g / 20 ... 2000 Hz in 3 axes and 10 cycles each
Protection class (DIN EN 60529)		IP54
Weight		approx. 275 g (incl. cable)

FSO = Full Scale Output

¹⁾ Specifications for digital outputs from page 59 onwards.

Article designation

WPS -	2100 -	MK77 -	E
			Output type: Encoder E (5 ... 24 VDC) Encoder E830 (8 ... 30 VDC)
			MK77 series
			Measuring range in mm

Low-cost draw-wire sensors wire**SENSOR** MK60 analog

Robust plastic housing

Customer-specific designs

Potentiometer, current or voltage output

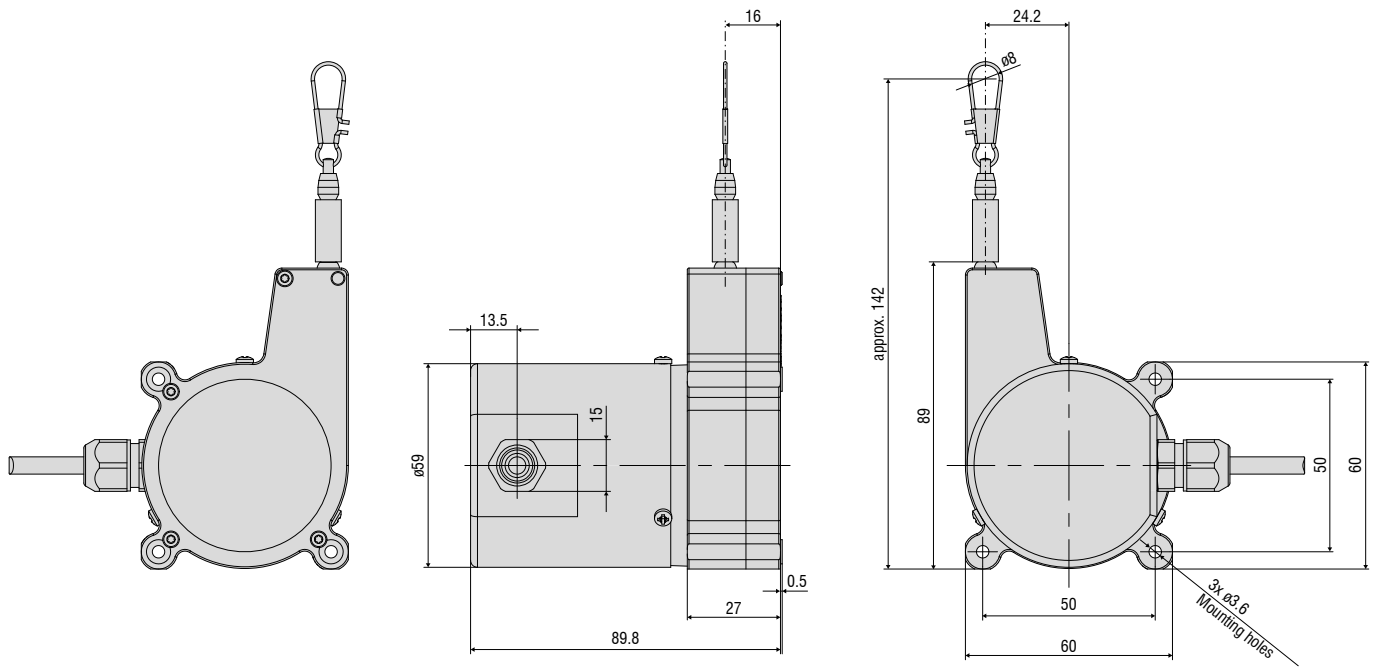

All dimensions in mm, not to scale

Model	WPS-1500-MK60	
Measuring range	1500 mm	
Analog output ¹⁾	Potentiometer, current, voltage	
Resolution	Hybrid potentiometer P10	towards infinity
Linearity	Hybrid potentiometer P10 ≤ ±0.15% FSO	≤ ±2.25 mm
Sensor element	Hybrid potentiometer	
Wire extension force (max.)	approx. 8 N	
Wire retraction force (min.)	approx. 1 N	
Wire acceleration (max.)	approx. 5 g	
Material	Housing	Glass-fiber reinforced plastic (PBT GF20)
	Measuring wire	Polyamide-coated stainless steel (ø 0.45 mm)
Wire mounting	Wire clip	
Installation	Mounting holes	
Temperature range	Storage	-20 ... +80 °C
	Operation	-20 ... +80 °C
Connection	integrated cable, radial, length 1 m	
Shock (DIN EN 60068-2-27)	50 g / 5 ms in 3 axes, 2 directions and 1000 shocks each	
Vibration (DIN EN 60068-2-6)	20 g / 20 ... 2000 Hz in 3 axes and 10 cycles each	
Protection class (DIN EN 60529)	IP65	
Weight	approx. 290 g (incl. cable)	

FSO = Full Scale Output

¹⁾ Specifications for analog outputs from page 58 onwards.

Article designation

WPS -	1500 -	MK60 -	CR -	P
				Output: P: potentiometer U: voltage I: current
			Connection CR: integrated cable, radial, 1 m	
		MK60 series		
Measuring range in mm				

Low-cost draw-wire sensors **wireSENSOR MK60 digital**

- Robust plastic housing
- Customer-specific designs
- Incremental encoder

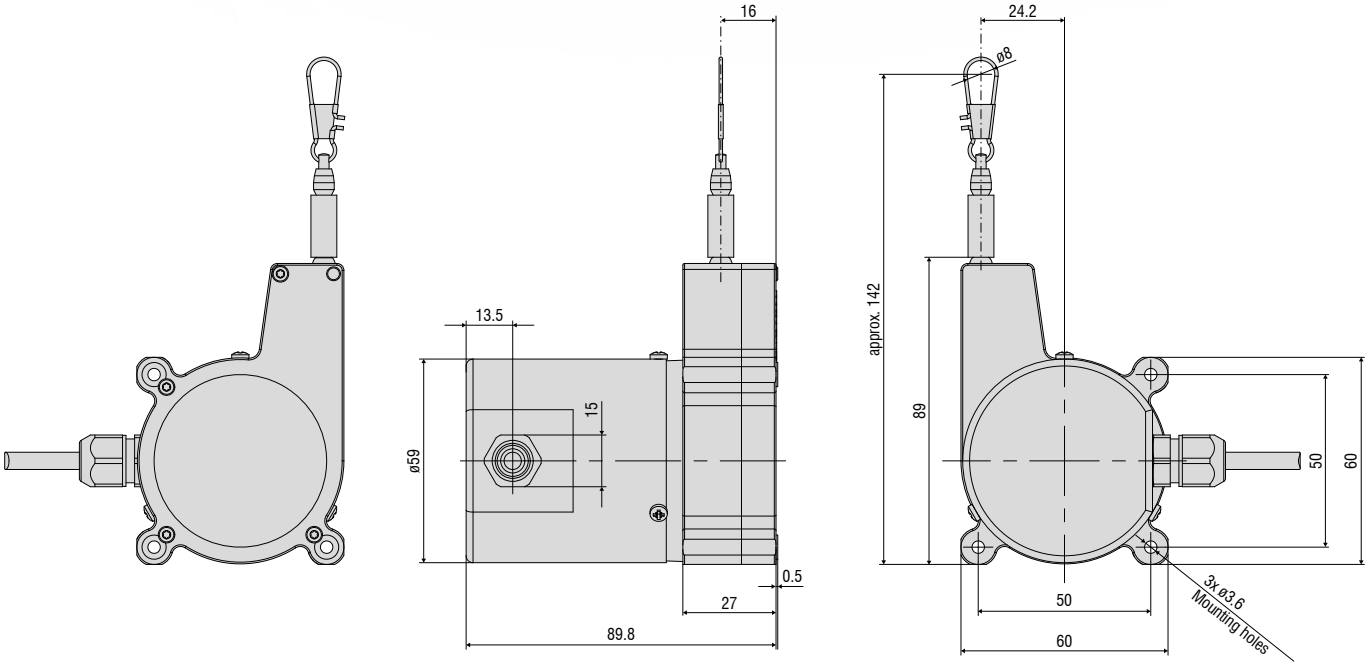

All dimensions in mm, not to scale

Model		WPS-2400-MK60
Measuring range		2400 mm
Digital output ¹⁾		TTL01 (A, B, 0) / TTL02 (A, \bar{A} , B, \bar{B} , 0)
Resolution		6.83 pulses/mm
		0.146 mm
Linearity	$\leq \pm 0.05\%$ FSO	$\leq \pm 1.2$ mm
Sensor element		Incremental encoder
Wire extension force (max.)		approx. 8 N
Wire retraction force (min.)		approx. 1 N
Wire acceleration (max.)		approx. 5 g
Material	Housing	Glass-fiber reinforced plastic (PBT GF20)
	Measuring wire	Polyamide-coated stainless steel (\varnothing 0.45 mm)
Wire mounting		Wire clip
Installation		Mounting holes
Temperature range	Storage	-20 ... +80 °C
	Operation	-20 ... +80 °C
Connection		integrated cable, radial, length 1 m
Shock (DIN EN 60068-2-27)		50 g / 5 ms in 3 axes, 2 directions and 1000 shocks each
Vibration (DIN EN 60068-2-6)		20 g / 20 ... 2000 Hz in 3 axes and 10 cycles each
Protection class (DIN EN 60529)		IP65
Weight		approx. 290 g (incl. cable)

FSO = Full Scale Output

¹⁾ Specifications for digital outputs from page 59 onwards.

Article designation

WPS -	2400	MK60 -	CR -	TTL01
				Output: TTL01: A, \bar{B} , 0 TTL02: A, A, B, \bar{B} , 0
				Connection CR: integrated cable, radial, 1 m
				MK60 series
				Measuring range in mm

Low-cost draw-wire sensors wire**SENSOR** MK88 analog

Robust plastic housing

Customer-specific designs

Potentiometer, current or voltage output

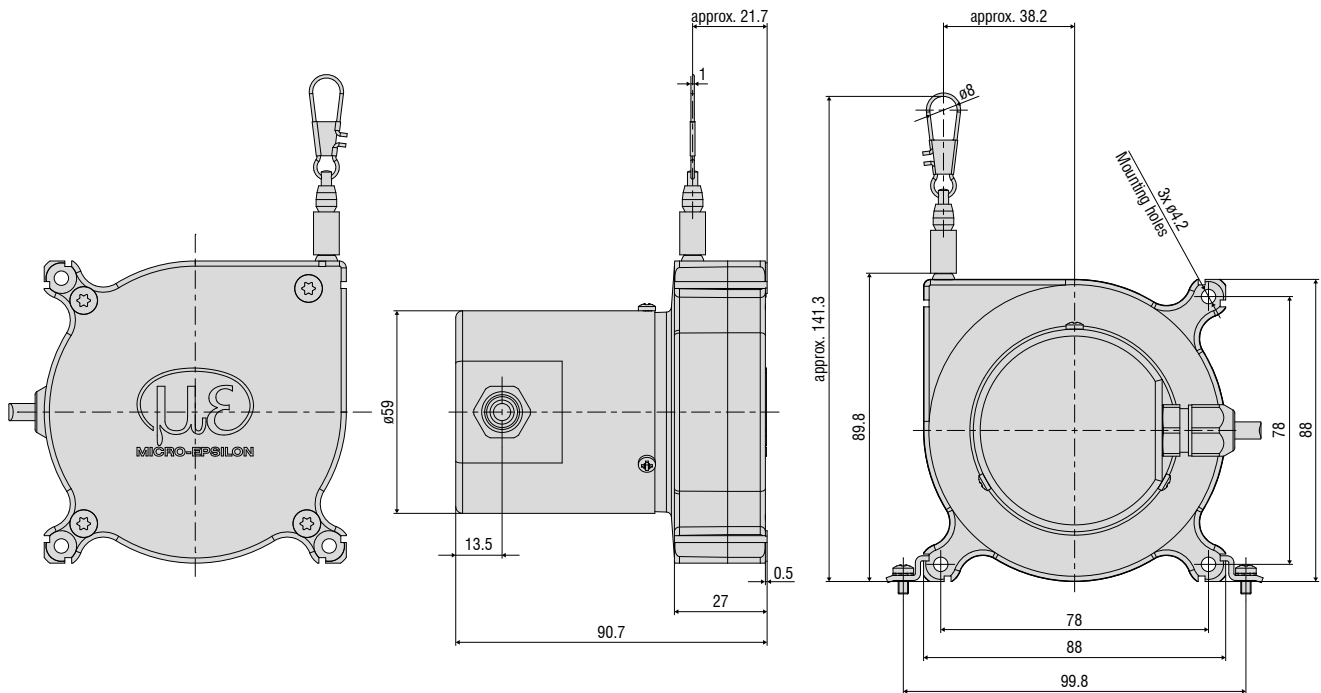

All dimensions in mm, not to scale

Model	WPS-2300-MK88	WPS-3500-MK88	WPS-5000-MK88
Measuring range	2300 mm	3500 mm	5000 mm
Analog output ¹⁾	Potentiometer, current, voltage		
Resolution	Hybrid potentiometer P10 towards infinity		
Linearity	Hybrid potentiometer P10 ≤ ±0.15% FSO	≤ ±3.45 mm	-
	Hybrid potentiometer P10 ≤ ±0.3% FSO	-	≤ ±10.5 mm
	Hybrid potentiometer P10 ≤ ±0.4% FSO	-	≤ ±20 mm
Sensor element	Hybrid potentiometer		
Wire extension force (max.)	approx. 9 N		
Wire retraction force (min.)	approx. 4 N		
Wire acceleration (max.)	approx. 7 g		
Material	Housing	Glass-fiber reinforced plastic (PA 6 GF30)	
	Protection cap	Glass-fiber reinforced plastic (PBT GF20)	
	Measuring wire	Polyamide-coated stainless steel (ø 0.45 mm)	
Wire mounting	Wire clip		
Installation	Mounting holes or mounting grooves on the sensor housing		
Temperature range	Storage	-20 ... +80 °C	
	Operation	-20 ... +80 °C (on request -40 ... +85 °C)	
Connection	integrated cable, radial, length 1 m		
Shock (DIN EN 60068-2-27)	50 g / 10 ms in 3 axes, 2 directions and 1000 shocks each		
Vibration (DIN EN 60068-2-6)	20 g / 20 ... 2000 Hz in 3 axes and 10 cycles each		
Protection class (DIN EN 60529)	IP65 (on request IP67)		
Weight	approx. 400 - 430 g (incl. cable)		

FSO = Full Scale Output

¹⁾ Specifications for analog outputs from page 58 onwards.

Article designation

WPS -	2300 -	MK88 -	CR -	P
				Output: P: potentiometer, U: voltage, I current
				Connection CR: integrated cable, radial, 1 m
				MK88 series
				Measuring range in mm

Low-cost draw-wire sensors wireSENSOR MK88 digital

Robust plastic housing

Customer-specific designs

CANopen Interface

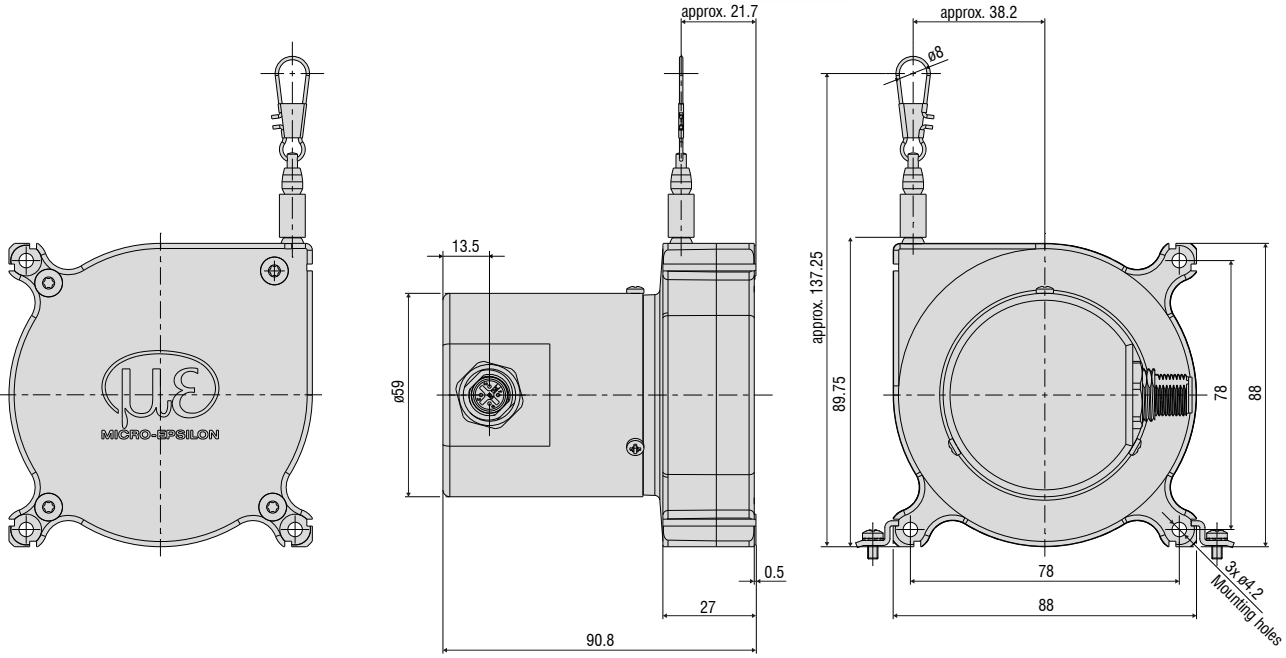

All dimensions in mm, not to scale

Model		WPS-2300-MK88	WPS-3500-MK88	WPS-5000-MK88
Measuring range		2300 mm	3500 mm	5000 mm
Digital interface ¹⁾		CANopen		
Resolution		0.56 mm	0.85 mm	1.22 mm
Linearity	Hybrid potentiometer P10	≤ ±0.15% FSO	≤ ±3.45 mm	-
	Hybrid potentiometer P10	≤ ±0.3% FSO	-	≤ ±10.5 mm
	Hybrid potentiometer P10	≤ ±0.4% FSO	-	≤ ±20 mm
Sensor element		Hybrid potentiometer		
Wire extension force (max.)		approx. 9 N		
Wire retraction force (min.)		approx. 4 N		
Wire acceleration (max.)		approx. 7 g		
Material	Housing	Glass-fiber reinforced plastic (PA 6 GF30)		
	Protection cap	Glass-fiber reinforced plastic (PBT GF20)		
	Measuring wire	Polyamide-coated stainless steel (ø 0.45 mm)		
Wire mounting		Wire clip		
Installation		Mounting holes or mounting grooves on the sensor housing		
Temperature range	Storage	-20 ... +80 °C		
	Operation	-20 ... +80 °C (on request -40 ... +85 °C)		
Connection		5-pole M12x1 connector, radial		
Shock (DIN EN 60068-2-27)		50 g / 10 ms in 3 axes, 2 directions and 1000 shocks each		
Vibration (DIN EN 60068-2-6)		20 g / 20 ... 2000 Hz in 3 axes and 10 cycles each		
Protection class (DIN EN 60529)		IP65 (on request IP67) ²⁾		
Weight		approx. 400 - 430 g (incl. cable)		

FSO = Full Scale Output

¹⁾ Specifications for digital outputs from page 59 onwards.

²⁾ With plug version only when connected

Article designation

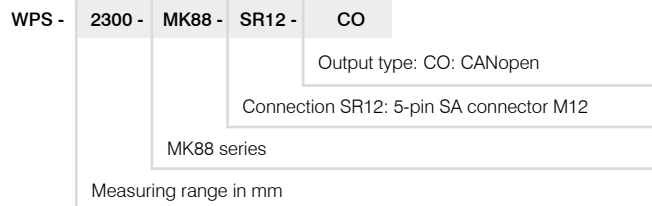

Low-cost draw-wire sensors wire**SENSOR** MK120 analog

Robust plastic housing

Customer-specific designs

Potentiometer, current or voltage output



Measuring ranges 3000, 5000 mm

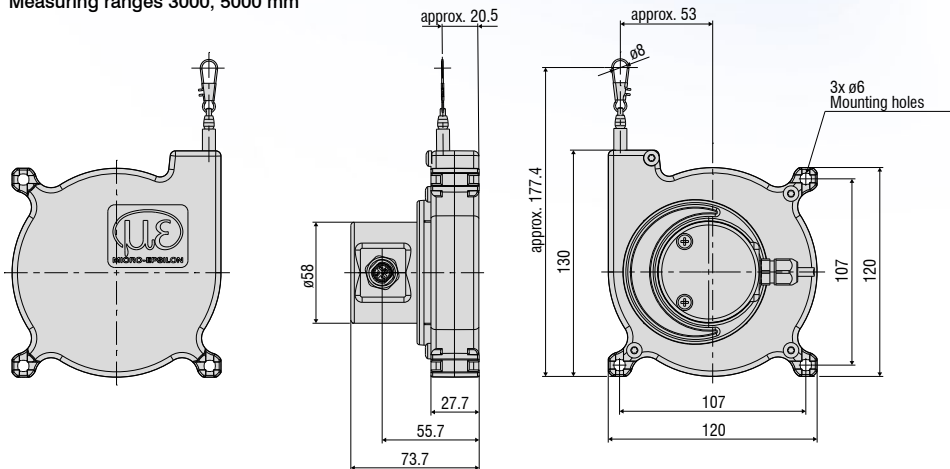

Measuring range 7500 mm

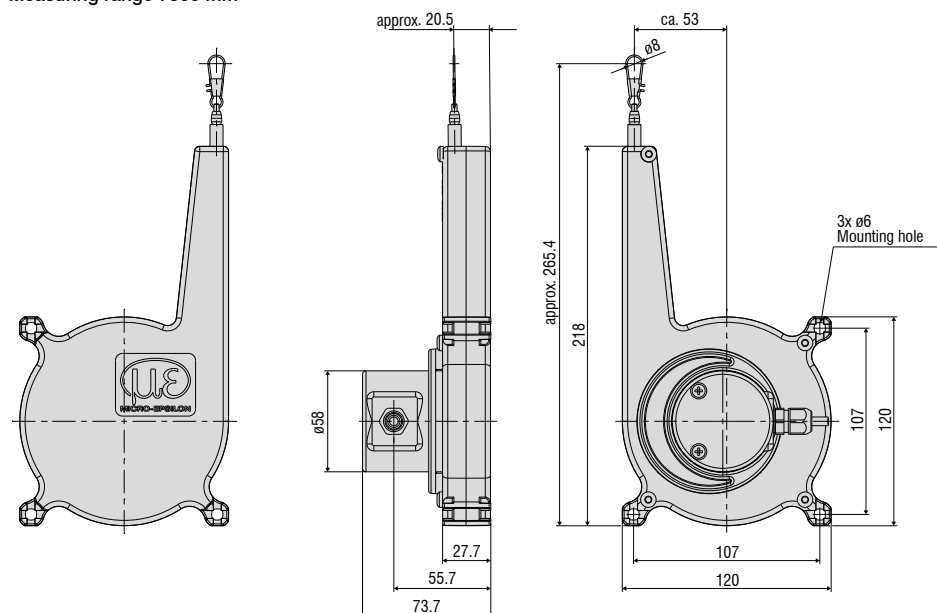

All dimensions in mm, not to scale

Model	WPS-3000-MK120	WPS-5000-MK120	WPS-7500-MK120	
Measuring range	3000 mm	5000 mm	7500 mm	
Analog output ¹⁾	Potentiometer, current, voltage			
Resolution	Hybrid potentiometer P10 towards infinity			
Linearity	Hybrid potentiometer P10 $\leq \pm 0.15\%$ FSO	$\leq \pm 4.5$ mm	$\leq \pm 7.5$ mm	$\leq \pm 11.25$ mm
Sensor element	Hybrid potentiometer			
Wire extension force (max.)	approx. 10 N			
Wire retraction force (min.)	approx. 4 N			
Wire acceleration (max.)	approx. 6 g			
Material	Housing	Plastics (PA 6)		
	Measuring wire	Polyamide-coated stainless steel (\varnothing 0.45 mm)		
Wire mounting	Wire clip			
Installation	Mounting holes or mounting grooves on the sensor housing			
Temperature range	Storage	-20 ... +80 °C		
	Operation	-20 ... +80 °C		
Connection	integrated cable, radial, length 1 m			
Shock (DIN EN 60068-2-27)	40 g / 6 ms in 3 axes, 2 directions and 3000 shocks each			
Vibration (DIN EN 60068-2-6)	3 g / 10 ... 5000 Hz in 3 axes and 10 cycles each			
Protection class (DIN EN 60529)	IP65			
Weight	approx. 850 g (incl. cable)			

F50 = Full Scale Output

¹⁾ Specifications for analog outputs from page 58 onwards.

Article designation

WPS -	3000 -	MK120 -	CR -	P
				Output: P: potentiometer, U: voltage, I current
				Connection CR: integrated cable, radial, 1 m
				MK120 series
				Measuring range in mm

Robust draw-wire sensors for OEM

wireSENSOR K100 analog

Durable and robust sensor design (IP67/IP69K)

Compact sensor with large measuring range

Large temperature range from -40 to +85 °C

Potentiometer, current or voltage output



Measuring ranges 1500, 2500 mm

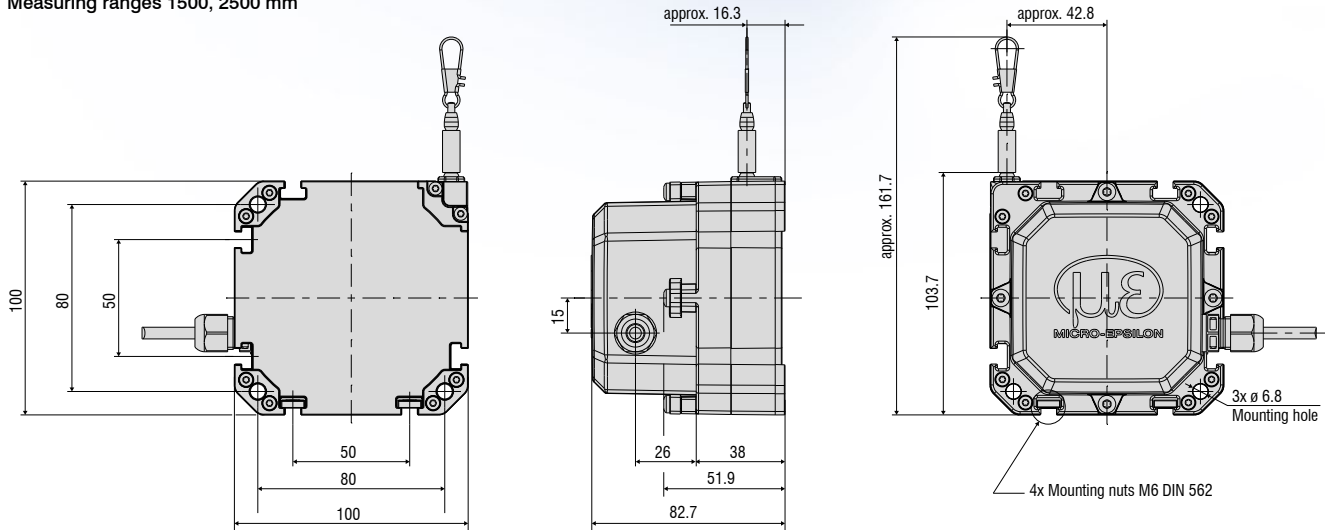

Measuring ranges 3500, 5000, 8000 mm

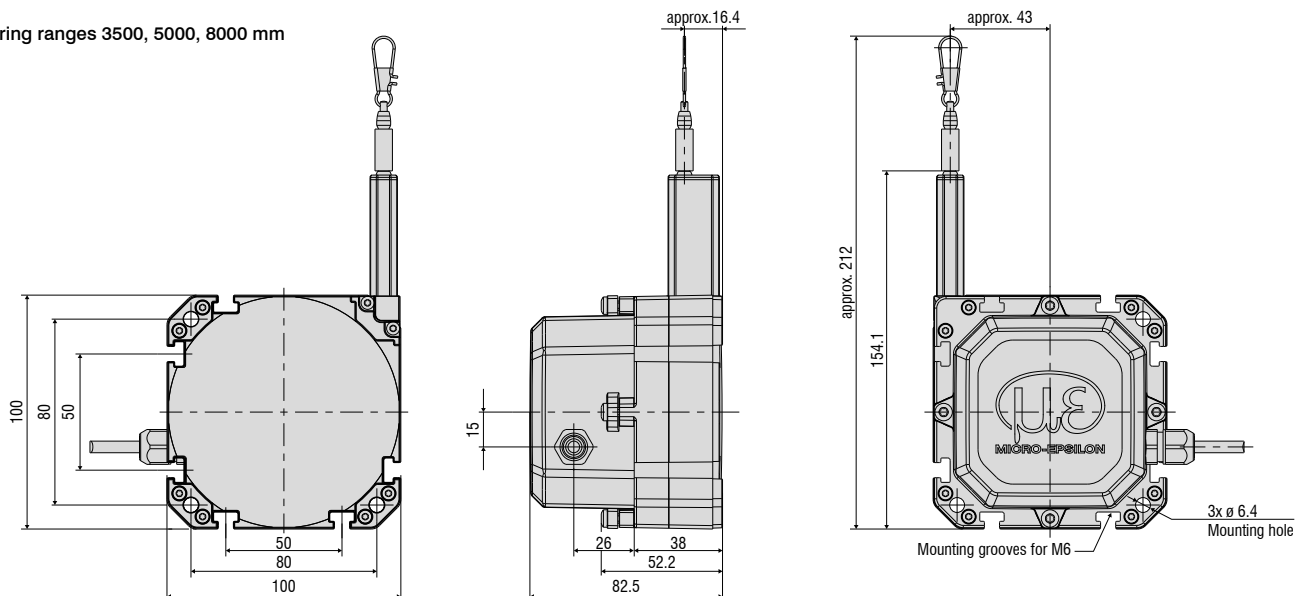

All dimensions in mm, not to scale

Model	WPS-1500-K100	WPS-2500-K100	WPS-3500-K100	WPS-5000-K100	WPS-8000-K100
Measuring range	1500 mm	2500 mm	3500 mm	5000 mm	8000 mm
Analog output ¹⁾	Potentiometer, current, voltage				
Resolution	towards infinity				
Linearity	≤ ±0.15% FSO	≤ ±2.25 mm	-	-	-
	≤ ±0.20% FSO	-	≤ ±5 mm	-	-
	≤ ±0.25% FSO	-	-	≤ ±8.75 mm	≤ ±12.5 mm
	≤ ±0.35% FSO	-	-	-	≤ ±28 mm
Sensor element	Hybrid potentiometer				
Wire extension force (max.)	approx. 10 N				
Wire retraction force (min.)	approx. 2 N				approx. 1.5 N
Wire acceleration (max.)	approx. 5 g				
Material	Housing	Glass-fiber reinforced plastic			
	Measuring wire	Polyamide-coated stainless steel (ø 0.61 mm)		Polyamide-coated stainless steel (ø 0.45 mm)	
Wire mounting	Wire clip				
Installation	Through-bores Ø 6.4 mm and mounting nuts (for M6) on the sensor housing				
Temperature range	Storage	-40 ... +85 °C			
	Operation	-40 ... +85 °C			
Connection	integrated cable, radial, length 1 m				
Shock (DIN EN 60068-2-27)	50 g / 8 ms in 3 axes, 2 directions and 1000 shocks each				
Vibration (DIN EN 60068-2-6)	5 g / 10 ... 150 Hz in 3 axes and 20 cycles each				
Protection class (DIN EN 60529)	IP67 / IP69K				
Weight	approx. 500 g				

FSO = Full Scale Output

¹⁾ Specifications for analog outputs from page 58 onwards.

Article designation

WPS -	1500 -	K100 -	CR -	P
			Output: P: potentiometer, U: voltage, I current	
			Connection CR: integrated cable, radial, 1 m	
		K100 series		
	Measuring range in mm			

Robust draw-wire sensors for OEM

wireSENSOR K100 digital

Durable and robust sensor design (IP67/IP69K)

Compact sensor with large measuring range

Large temperature range from -40 to +85 °C

CANopen Interface

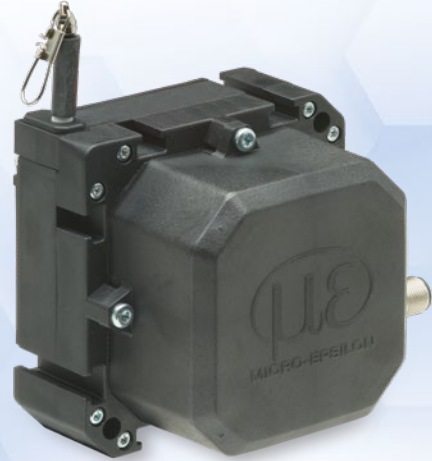

Measuring ranges 1500, 2500 mm

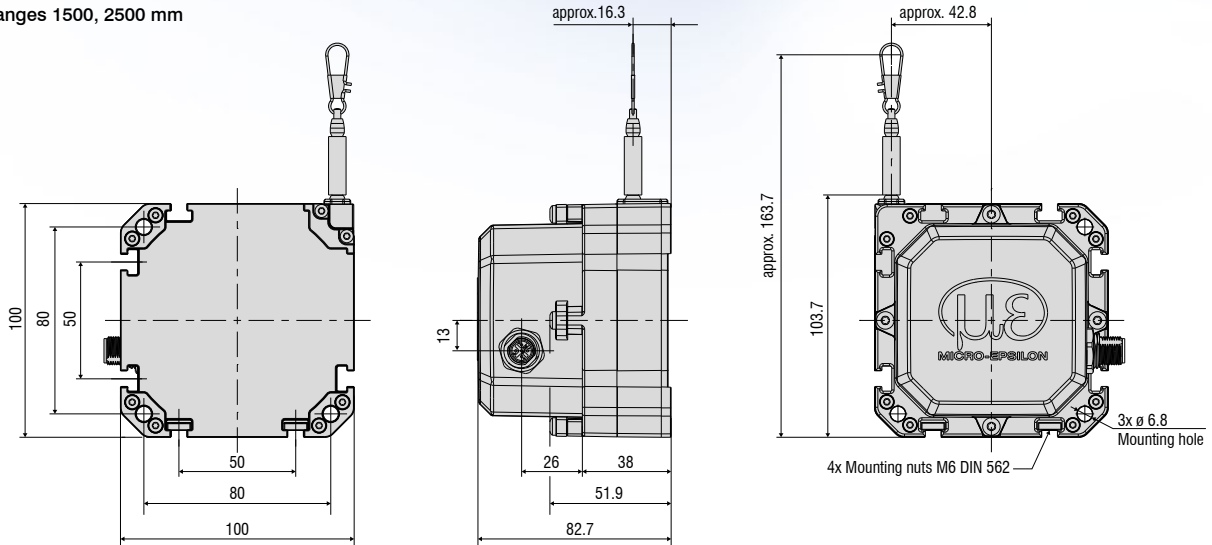

Measuring ranges 3500, 5000, 8000 mm

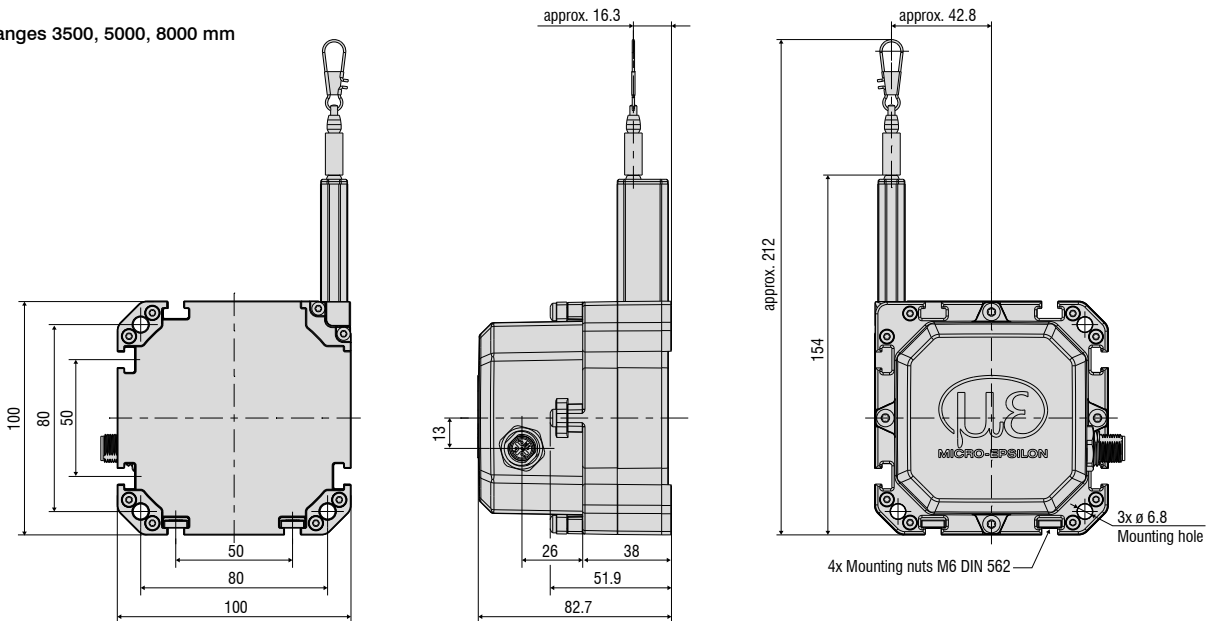

All dimensions in mm, not to scale

Model	WPS-1500-K100	WPS-2500-K100	WPS-3500-K100	WPS-5000-K100	WPS-8000-K100
Measuring range	1500 mm	2500 mm	3500 mm	5000 mm	8000 mm
Digital interface ¹⁾	CANopen				
Resolution	0.37 mm	0.61 mm	0.85 mm	1.22 mm	1.95 mm
Linearity	≤ ±0.15% FSO	≤ ±2.25 mm	-	-	-
	≤ ±0.20% FSO	-	≤ ±5 mm	-	-
	≤ ±0.25% FSO	-	-	≤ ±8.75 mm	≤ ±12.5 mm
	≤ ±0.35% FSO	-	-	-	≤ ±28 mm
Sensor element	Hybrid potentiometer				
Wire extension force (max.)	approx. 10 N				
Wire retraction force (min.)	approx. 2 N				approx. 1.5 N
Wire acceleration (max.)	approx. 5 g				
Material	Housing	Glass-fiber reinforced plastic			
	Measuring wire	Polyamide-coated stainless steel (ø 0.61 mm)		Polyamide-coated stainless steel (ø 0.45 mm)	
Wire mounting	Wire clip				
Installation	Through-bores Ø 6.4 mm and mounting nuts (for M6) on the sensor housing (optional: for series applications with additional M12 socket)				
Temperature range	Storage	-40 ... +85 °C			
	Operation	-40 ... +85 °C			
Connection	5-pole M12x1 connector				
Shock (DIN EN 60068-2-27)	50 g / 8 ms in 3 axes, 2 directions and 1000 shocks each				
Vibration (DIN EN 60068-2-6)	5 g / 10 ... 150 Hz in 3 axes and 20 cycles each				
Protection class (DIN EN 60529)	IP67 / IP69K ²⁾				
Weight	approx. 500 g				

FSO = Full Scale Output

¹⁾ Specifications for digital outputs from page 59 onwards. Available with SAE J1939 on request.

²⁾ With plug version only when connected. Available on request with two 5-pin M12x2 connectors (male-female, looped through).

Article designation

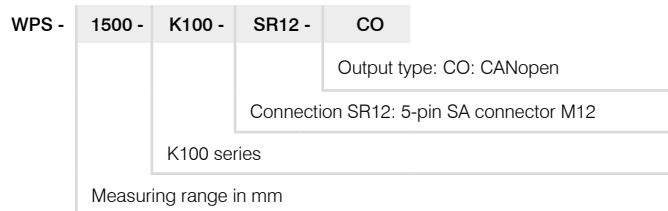

Industrial draw-wire sensors wire**SENSOR** P60 analog

Robust aluminum profile housing

Customer-specific designs

Potentiometer, current or voltage output



Output P

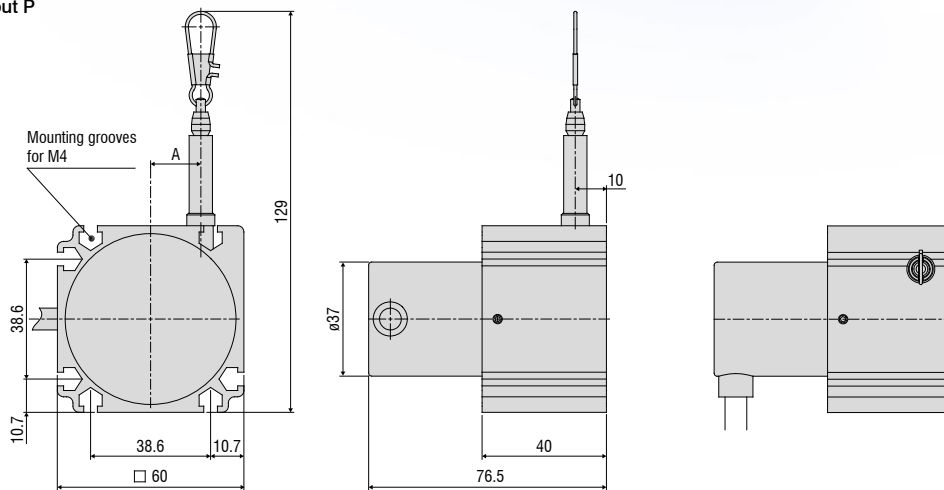

Measuring range (mm)	A (mm)
100 / 300 / 500 / 1000	approx. 16.15
150 / 750 / 1500	approx. 24.2

Output U/I

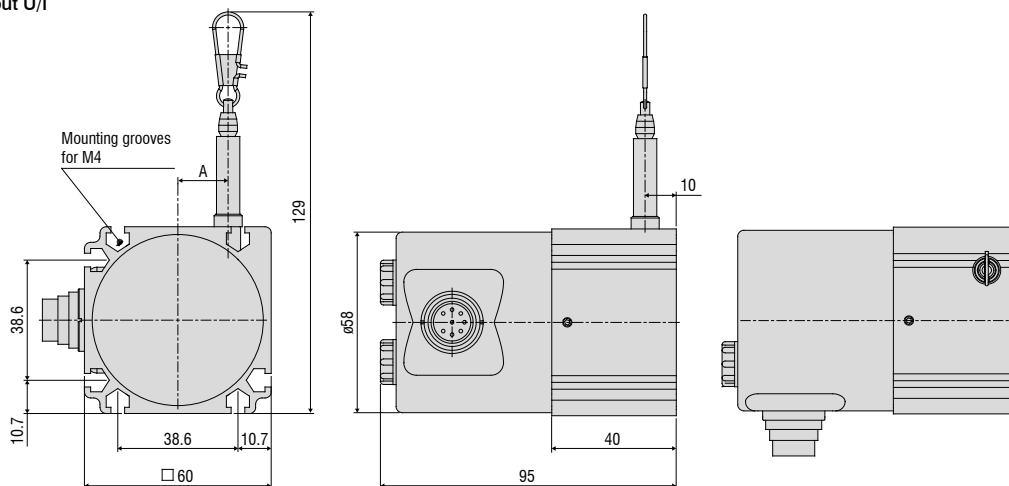

All dimensions in mm, not to scale

Model	WDS-100-P60	WDS-150-P60	WDS-300-P60	WDS-500-P60	WDS-750-P60	WDS-1000-P60	WDS-1500-P60	
Measuring range	100 mm	150 mm	300 mm	500 mm	750 mm	1000 mm	1500 mm	
Analog output ¹⁾	Potentiometer, current, voltage							
Resolution	towards infinity							
Linearity	Hybrid potentiometer P10 $\leq \pm 0.1\%$ FSO	-	-	-	$\leq \pm 0.5$ mm	$\leq \pm 0.75$ mm	$\leq \pm 1$ mm	$\leq \pm 1.5$ mm
	Hybrid potentiometer P25 $\leq \pm 0.25\%$ FSO	-	-	$\leq \pm 0.75$ mm	-	-	-	-
	Conductive plastic/wire potentiometer P25 $\leq \pm 0.5\%$ FSO	$\leq \pm 0.5$ mm	$\leq \pm 0.75$ mm	-	-	-	-	-
Sensor element	Conductive plastic/wire potentiometer		Hybrid potentiometer					
Wire extension force (max.)	approx. 7.5 N	approx. 5.5 N	approx. 7.5 N	approx. 7.5 N	approx. 5.5 N	approx. 7.5 N	approx. 5.5 N	
Wire retraction force (min.)	approx. 6.5 N	approx. 4.5 N	approx. 6 N	approx. 6 N	approx. 4 N	approx. 5 N	approx. 3.5 N	
Wire acceleration (max.)	approx. 10 ... 15 g (depending on measuring range)							
Material	Housing	Aluminum						
	Measuring wire	Polyamide-coated stainless steel (\varnothing 0.45 mm)						
Wire mounting	Wire clip							
Installation	Mounting grooves on the sensor housing							
Temperature range	Storage	-20 ... +80 °C						
	Operation	-20 ... +80 °C						
Connection	Potentiometer	integrated cable, radial, length 1 m						
	Current, voltage	pluggable cable via 8-pin flange connector (DIN45326), radial						
Shock (DIN EN 60068-2-27)	50 g / 10 ms in 3 axes, 1000 shocks each							
Vibration (DIN EN 60068-2-6)	20 g / 10 ... 2000 Hz in 3 axes, 10 cycles each							
Protection class (DIN EN 60529)	IP65 ²⁾							
Weight	approx. 370 g							

FSO = Full Scale Output

¹⁾ Specifications for analog outputs from page 58 onwards.

²⁾ With plug version only when connected.

Article designation

WDS -	100 -	P60 -	CR -	P
				Output type: P: potentiometer (with connection CR) U: voltage (with connection SR) I: current (with connection SR)
				Connection: SR: radial plug CR: integrated cable, radial, 1 m
				P60 series
				Measuring range in mm

Industrial draw-wire sensors

wireSENSOR P60 digital

Robust aluminum profile housing

Customer-specific designs

Absolute or incremental encoder

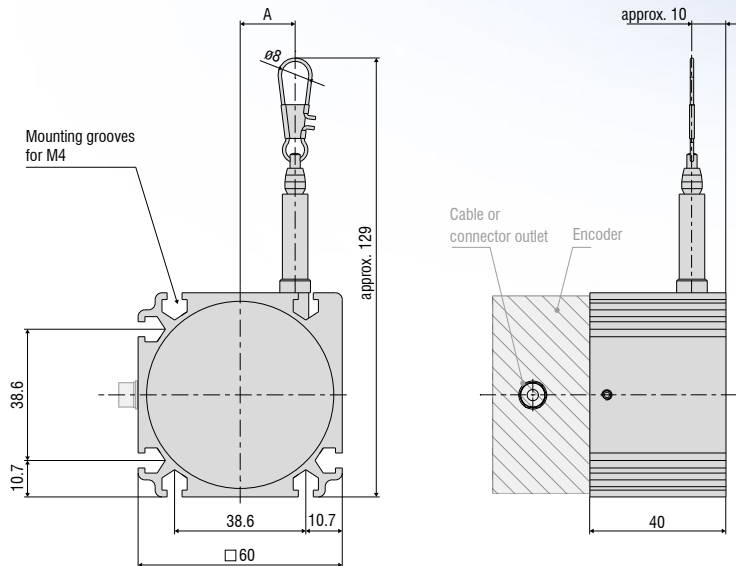

MR (mm)	A (mm)
1000	approx. 16.15
1500	approx. 24.2

HTL/TTL output

SSI output

Output CO/PB

Output PN/ENIP/CAT

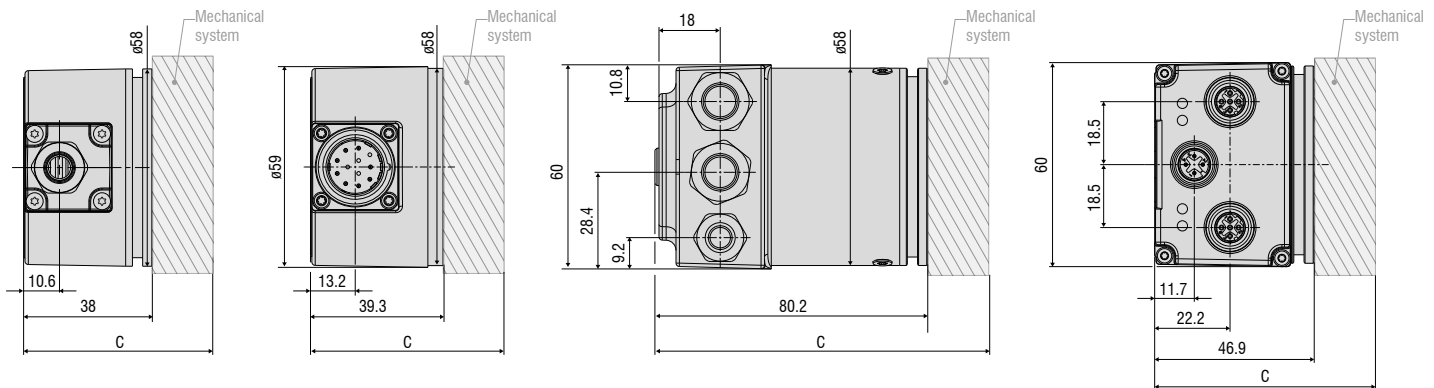

All dimensions in mm, not to scale

Total length mechanics + Encoder (C)				
Output	HTL/TTL	SSI	CO/PB	PN/ENIP/CAT
C (mm)	78	79.3	120.3	86.9

Model	WDS-1000-P60	WDS-1500-P60
Measuring range	1000 mm	1500 mm
Digital interface ¹⁾	PROFINET, Profibus DP, CANopen, EtherNet/IP, EtherCAT	
Digital output ¹⁾	HTL, TTL, SSI	
Resolution	HTL, TTL 0.067 mm (15 pulses/mm)	0.1 mm (10 pulses/mm)
	SSI, PROFINET, Profibus DP, CANopen, EtherNet/IP, EtherCAT 0.012 mm	0.018 mm
Linearity	≤ ±0.02% FSO	
Sensor element	Incremental/absolute encoder	
Wire extension force (max.)	approx. 7.5 N	approx. 5.5 N
Wire retraction force (min.)	approx. 5 N	approx. 3.5 N
Wire acceleration (max.)	approx. 10 g	approx. 15 g
Material	Housing	Aluminum
	Measuring wire	Polyamide-coated stainless steel (ø 0.45 mm)
Wire mounting	Wire clip	
Installation	Mounting grooves on the sensor housing	
Temperature range	Storage	-20 ... +80 °C
	Operation	-20 ... +80 °C
Connection	HTL, TTL	integrated cable, radial, length 1 m
	SSI	12-pin flange connector, radial
	PROFINET, Profibus DP, CANopen, EtherNet/IP, EtherCAT	Bus cover
Shock (DIN EN 60068-2-27)	50 g / 10 ms in 3 axes, 1000 shocks each	
Vibration (DIN EN 60068-2-6)	20 g / 10 ... 2000 Hz in 3 axes, 10 cycles each	
Protection class (DIN EN 60529)	IP65 ²⁾	
Weight	approx. 1 kg	

FSO = Full Scale Output

¹⁾ Specifications for digital outputs from page 59 onwards.

²⁾ With plug version only when connected

Article designation

WDS -	1000 -	P60 -	CR -	TTL
				Output: HTL TTL CO: CANopen PB: Profibus DP SSI: Gray Code PN: PROFINET ENIP: EtherNet/IP CAT: EtherCAT
				Connection: SR (with SSI output): plug, radial CR (with HTL, TTL output): integrated cable, radial, 1 m BH (with CO, PB, PN, ENIP, CAT output): bus cover
				P60 series
				Measuring range in mm

Industrial draw-wire sensors wireSENSOR P96 analog

Robust aluminum profile housing

Customer-specific designs

Potentiometer, current or voltage output

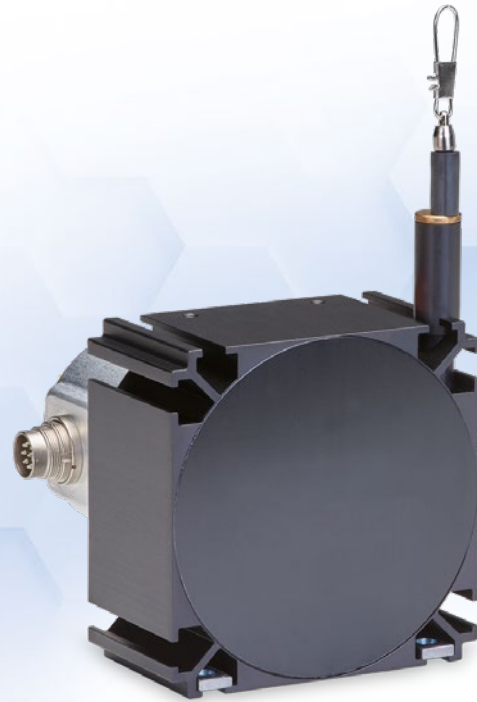

Output P

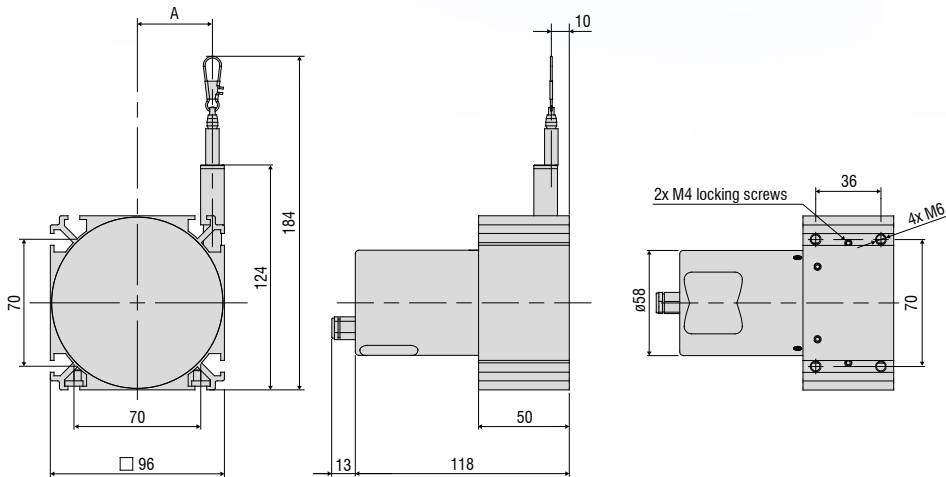

Measuring range (mm)	A (mm)
2000	approx. 32
2500	approx. 41.4

Output U/I

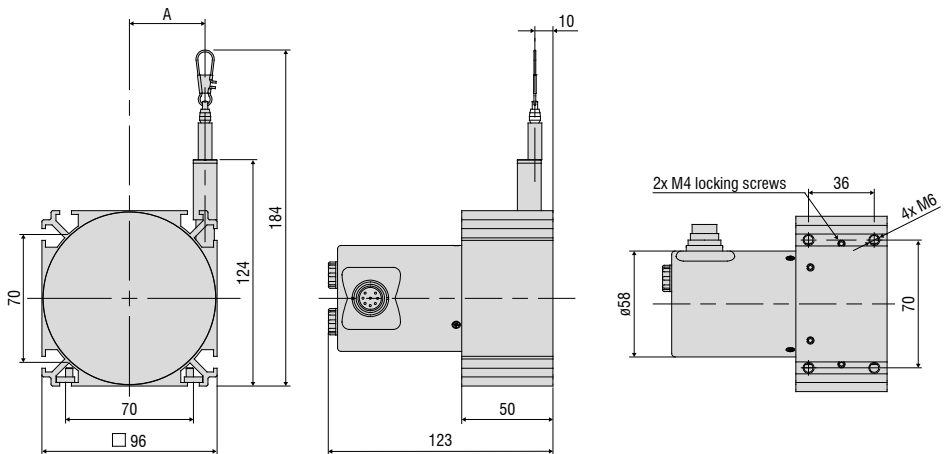

All dimensions in mm, not to scale

Model	WDS-2000-P96	WDS-2500-P96
Measuring range	2000 mm	2500 mm
Analog output ¹⁾	Potentiometer, current, voltage	
Resolution	towards infinity	
Linearity $\leq \pm 0.1\%$ FSO	$\leq \pm 2$ mm	$\leq \pm 2.5$ mm
Sensor element	Hybrid potentiometer	
Wire extension force (max.)	approx. 11 N	approx. 9 N
Wire retraction force (min.)	approx. 7.5 N	approx. 5.5 N
Wire acceleration (max.)	approx. 8 g	
Material	Housing	Aluminum
	Measuring wire	Polyamide-coated stainless steel (\varnothing 0.8 mm)
Wire mounting	Wire clip	
Installation	Mounting grooves on the sensor housing	
Temperature range	Storage	-20 ... +80 °C
	Operation	-20 ... +80 °C
Connection	Potentiometer	integrated cable, axial, length 1 m
	Current, voltage	pluggable cable via 8-pin flange connector (DIN45326), radial
Shock (DIN EN 60068-2-27)	50 g / 10 ms in 3 axes, 1000 shocks each	
Vibration (DIN EN 60068-2-6)	20 g / 20 ... 2000 Hz in 3 axes, 10 cycles each	
Protection class (DIN EN 60529)	IP65 ²⁾	
Weight	approx. 1.1 kg	

FSO = Full Scale Output

¹⁾ Specifications for analog outputs from page 58 onwards.

²⁾ With plug version only when connected.

Article designation

WDS -	2000 -	P96 -	CA -	P
				Output type: P: potentiometer (with CA connection) U: voltage (with connection SR) I: current (with connection SR)
				Connection: SR: radial plug CA: integrated cable, axial, 1 m
				P96 series
				Measuring range in mm

Industrial draw-wire sensors

wire**SENSOR** P96 digital

Robust aluminum profile housing

Absolute or incremental encoder

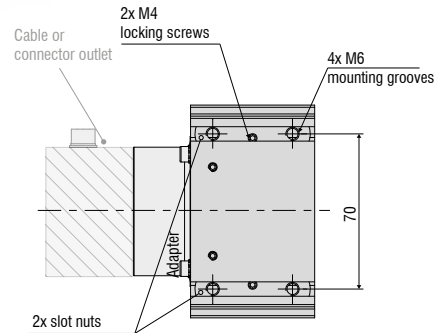
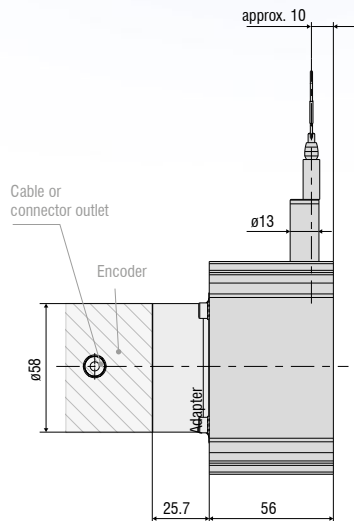
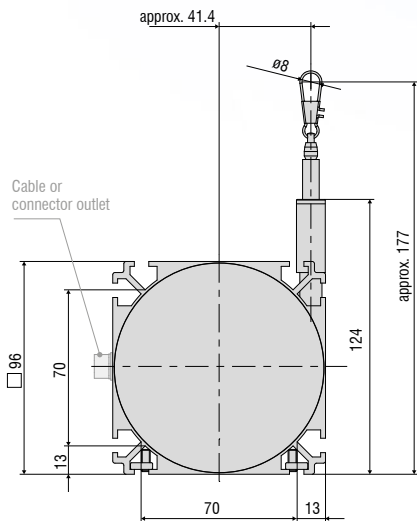
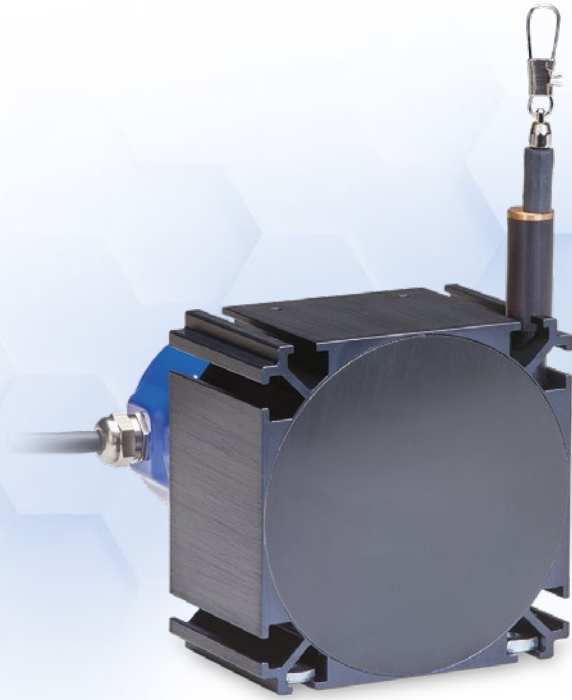

HTL/TTL output

SSI output

Output CO/PB

Output PN / ENIP / CAT

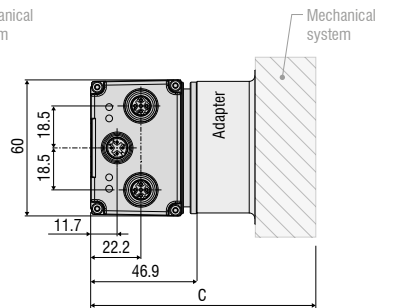
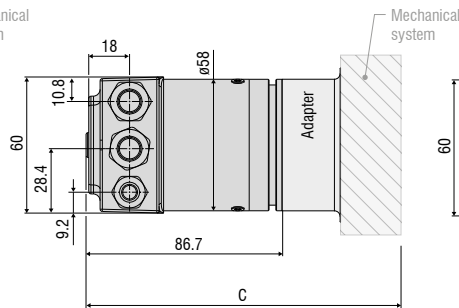
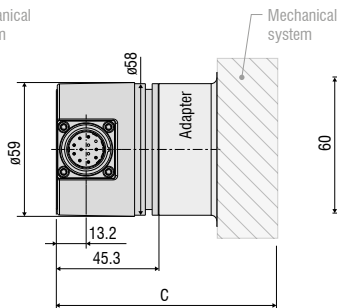
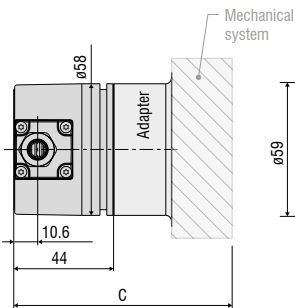

All dimensions in mm, not to scale

Total length mechanics + Encoder (C)				
Output	HTL/TTL	SSI	CO/PB	PN /ENIP/CAT
C (mm)	125.7	127.0	168.4	128.6

Model		WDS-3000-P96
Measuring range		3000 mm
Digital interface ¹⁾		PROFINET, Profibus DP, CANopen, EtherNet/IP, EtherCAT
Digital output ¹⁾		HTL, TTL, SSI
Resolution	HTL, TTL	0.087 mm (11.53 pulses/mm)
	SSI, PROFINET Profibus DP, CANopen, EtherNet/IP, EtherCAT	0.032 mm
Linearity		≤ ±0.02% FSO
Sensor element		Incremental/absolute encoder
Wire extension force (max.)		approx. 9 N
Wire retraction force (min.)		approx. 5.5 N
Wire acceleration (max.)		approx. 7 g
Material	Housing	Aluminum
	Measuring wire	Polyamide-coated stainless steel (ø 0.8 mm)
Wire mounting		Wire clip
Installation		Mounting grooves on the sensor housing
Temperature range	Storage	-20 ... +80 °C
	Operation	-20 ... +80 °C
Connection	HTL, TTL	integrated cable, radial, length 1 m
	SSI	12-pin flange connector, radial
	PROFINET Profibus DP, CANopen, EtherNet/IP, EtherCAT	Bus cover
Shock (DIN EN 60068-2-27)		50 g / 10 ms in 3 axes, 1000 shocks each
Vibration (DIN EN 60068-2-6)		20 g / 20 ... 2000 Hz in 3 axes, 10 cycles each
Protection class (DIN EN 60529)		IP65 ²⁾
Weight		approx. 1.7 kg

FSO = Full Scale Output

¹⁾ Specifications for digital outputs from page 59 onwards.

²⁾ With plug version only when connected

Article designation

WDS -	3000 -	P96 -	CR -	TTL
				Output: HTL TTL CO: CANopen PB: Profibus DP SSI: Gray Code PN: PROFINET ENIP: EtherNet/IP CAT: EtherCAT
				Connection: SR (with SSI output): plug, radial CR (with HTL, TTL output): integrated cable, radial, 1 m BH (with CO, PB, PN, ENIP, CAT output): bus cover
				P96 series
				Measuring range in mm

Industrial draw-wire sensors wireSENSOR P115 analog

Robust aluminum profile housing

Customer-specific designs

Potentiometer, current or voltage output



Measuring range 3000/4000/5000 mm

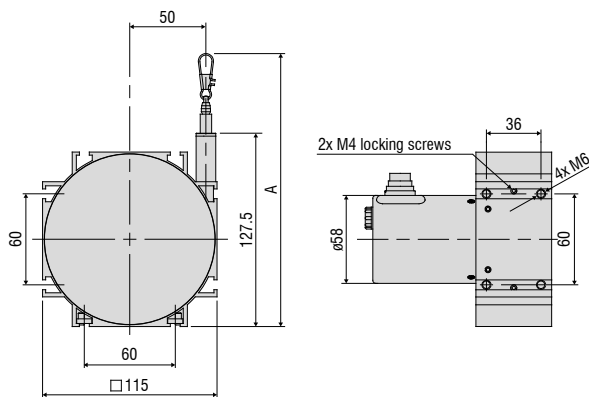

Output U/I

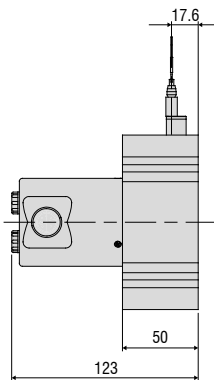

Output P

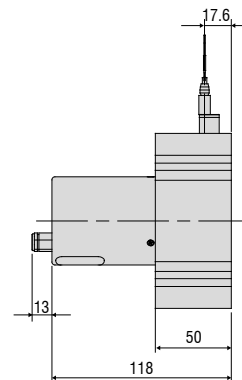

Measuring range (mm)	A (mm)
3000	approx. 186
4000 / 5000	approx. 180

Measuring range 7500/10000/15000 mm

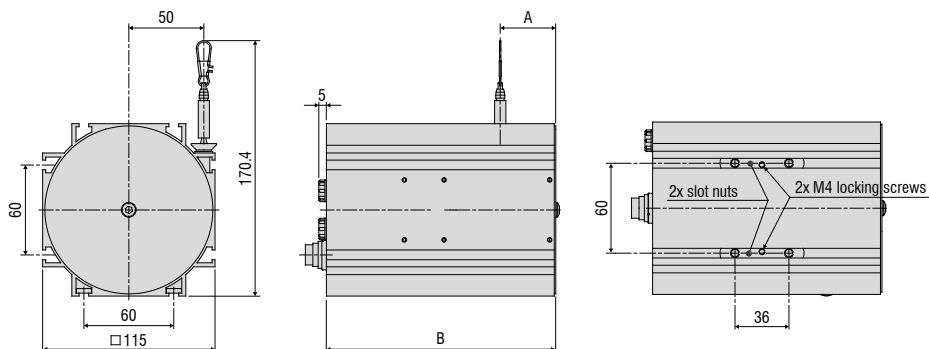

Measuring range (mm)	A (mm)	B (mm)
7500	37	153
10000	44.5	198
15000	60.5	228

All dimensions in mm, not to scale

Model	WDS-3000-P115	WDS-4000-P115	WDS-5000-P115	WDS-7500-P115	WDS-10000-P115	WDS-15000-P115
Measuring range	3000 mm	4000 mm	5000 mm	7500 mm	10000 mm	15000 mm
Analog output ¹⁾	Potentiometer, current, voltage					
Resolution	towards infinity					
Linearity	≤ ±0.1% FSO	≤ ±3 mm	-	-	-	-
	≤ ±0.15% FSO	-	≤ ±6 mm	≤ ±7.5 mm	≤ ±11.3 mm	≤ ±15 mm
Sensor element	Hybrid potentiometer					
Wire extension force (max.)	approx. 8 N	approx. 8.5 N	approx. 9 N	approx. 24 N	approx. 21 N	approx. 25 N
Wire retraction force (min.)	approx. 4 N	approx. 4 N	approx. 4 N	approx. 8 N	approx. 8 N	approx. 8 N
Wire acceleration (max.)	approx. 6 g					
Material	Housing	Aluminum				
	Measuring wire	Polyamide-coated stainless steel (ø 0.45 mm)			Polyamide-coated stainless steel (ø 1 mm)	
Wire mounting	Wire clip					
Installation	Mounting grooves on the sensor housing					
Temperature range	Storage	-20 ... +80 °C				
	Operation	-20 ... +80 °C				
Connection	Potentiometer	integrated cable, axial, length 1 m				
	Current, voltage	pluggable cable via 8-pin flange connector (DIN45326), radial				
Shock (DIN EN 60068-2-27)	50 g / 10 ms in 3 axes, 1000 shocks each					
Vibration (DIN EN 60068-2-6)	20 g / 20 ... 2000 Hz in 3 axes, 10 cycles each					
Protection class (DIN EN 60529)	IP65 ²⁾					
Weight	approx. 1.1 kg		approx. 2.2 kg		approx. 3.2 kg	approx. 3.5 kg

FSO = Full Scale Output

¹⁾ Specifications for analog outputs from page 58 onwards.

²⁾ With plug version only when connected.

Article designation

WDS -	3000 -	P115 -	CA -	P
				P: potentiometer: CA connection with P115-3000/4000/5000 SA connection with P115-7500/10000/15000 U/I: voltage/current SR connection with P115-3000/4000/5000 SA connection with P115-7500/10000/15000
				Connection: SR: radial plug SA: axial plug CA: integrated cable, axial, 1 m
				P115 series
				Measuring range in mm

Industrial draw-wire sensors wireSENSOR P115 digital

Robust aluminum profile housing

Customer-specific designs

Absolute or incremental encoder

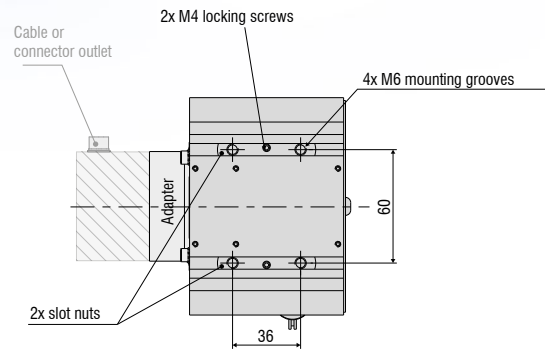
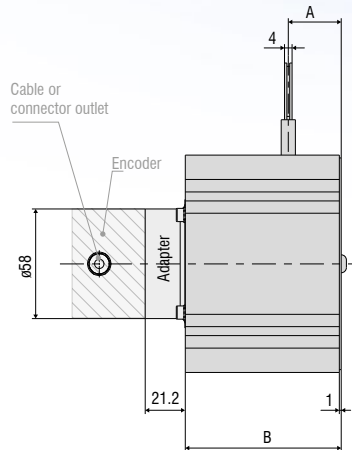
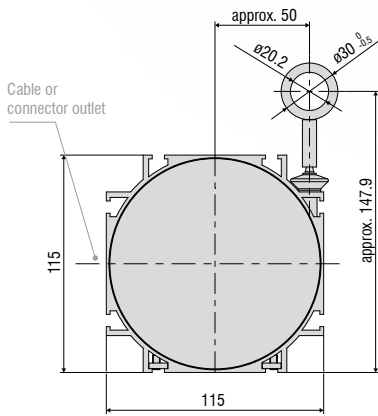

HTL/TTL output

SSI output

Output CO/PB

Output PN / ENIP / CAT

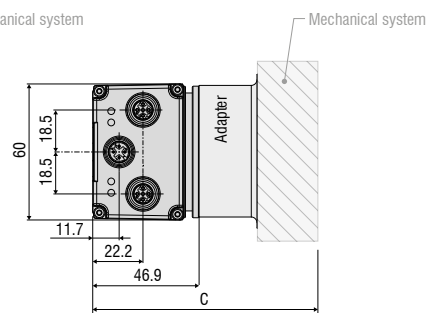
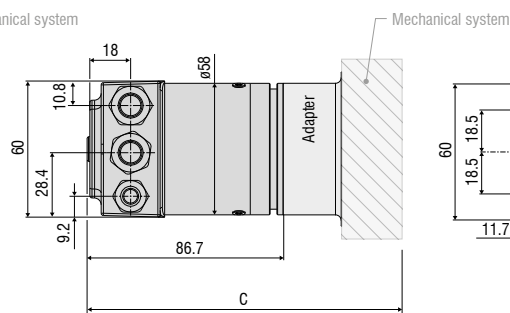
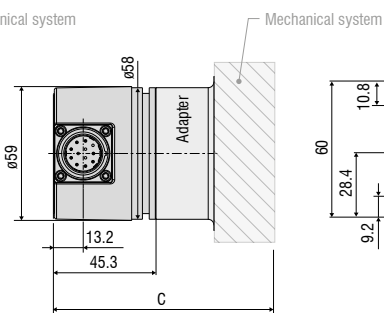
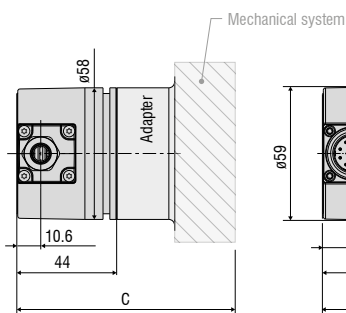

All dimensions in mm, not to scale

MR (mm)	A (mm)	B (mm)
5000	approx. 28	82.5
7500	approx. 37	105.5
10000	approx. 44.5	148.5
15000	approx. 61	180.5

Total length mechanics + Encoder (C)					
Output	HTL/TTL	SSI	CO/PB	PN/ENIP/CAT	
C (mm)	MR 5000	147.7	149.0	190.4	150.6
	MR 7500	170.7	172.0	213.4	173.6
	MR 10000	213.7	215.0	256.4	216.6
	MR 15000	245.7	247.0	288.4	248.6

Model	WDS-5000-P115	WDS-7500-P115	WDS-10000-P115	WDS-15000-P115
Measuring range	5000 mm	7500 mm	10000 mm	15000 mm
Digital interface ¹⁾	PROFINET, Profibus DP, CANopen, EtherNet/IP, EtherCAT			
Digital output ¹⁾	HTL, TTL, SSI			
Resolution	HTL, TTL 0.105 mm (9.52 pulses/mm)			
	SSI, PROFINET, Profibus DP, CANopen, EtherNet/IP, EtherCAT 0.038 mm			
Linearity	≤ ±0.01% FSO	-	-	≤ ±1 mm
	≤ ±0.02% FSO	≤ ±1 mm	≤ ±1.5 mm	-
Sensor element	Incremental/absolute encoder			
Wire extension force (max.)	approx. 16 N	approx. 24 N	approx. 21 N	approx. 25 N
Wire retraction force (min.)	approx. 4 N	approx. 8 N	approx. 8 N	approx. 8 N
Wire acceleration (max.)	approx. 5 g	approx. 6 g	approx. 3 g	approx. 3 g
Material	Housing	Aluminum		
	Measuring wire	Polyamide-coated stainless steel (ø 1 mm)		
Wire mounting	Eyelet (ø 20.2 mm)			
Installation	Mounting grooves on the sensor housing			
Temperature range	Storage	-20 ... +80 °C		
	Operation	-20 ... +80 °C		
Connection	HTL, TTL	integrated cable, radial, length 1 m		
	SSI	12-pin flange connector, radial		
	PROFINET, Profibus DP, CANopen, EtherNet/IP, EtherCAT	Bus cover		
Shock (DIN EN 60068-2-27)	50 g / 10 ms in 3 axes, 1000 shocks each			
Vibration (DIN EN 60068-2-6)	20 g / 20 ... 2000 Hz in 3 axes, 10 cycles each			
Protection class (DIN EN 60529)	IP65 ²⁾			
Weight	approx. 2 kg	approx. 2.5 kg	approx. 3.5 kg	approx. 4.5 kg

FSO = Full Scale Output

¹⁾ Specifications for digital outputs from page 59 onwards.

²⁾ With plug version only when connected

Article designation

WDS -	5000 -	P115 -	CR -	TTL
				Output: HTL TTL CO: CANopen PB: Profibus DP SSI: Gray Code PN: PROFINET ENIP: EtherNET/IP CAT: EtherCAT
				Connection: SR (with SSI output): plug, radial CR (with HTL, TTL output): integrated cable, radial, 1 m BH (with CO, PB, PN, ENIP, CAT output): bus cover
				P115 series
				Measuring range in mm

Draw-wire long-range sensors wire**SENSOR** P200 digital

Robust aluminum profile housing

Customer-specific designs

Absolute or incremental encoder

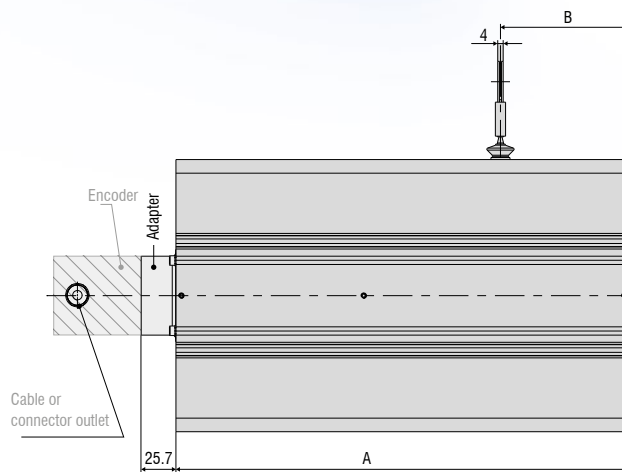
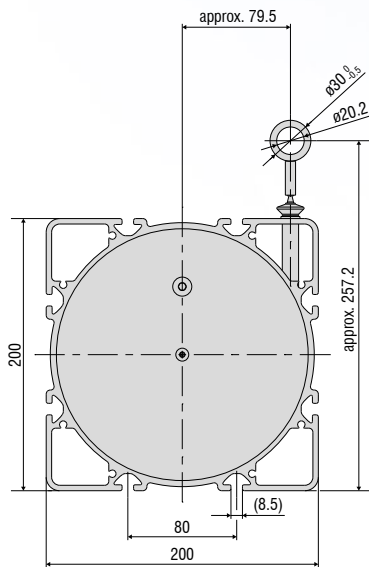

MR (mm)	A (mm)	B (mm)
30000	268	75
40000	300	95
50000	333.5	95

HTL/TTL output

SSI output

Output CO / PB

Output PN / ENIP / CAT

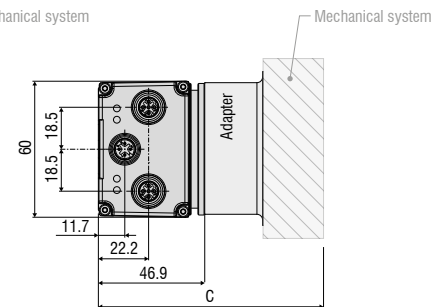
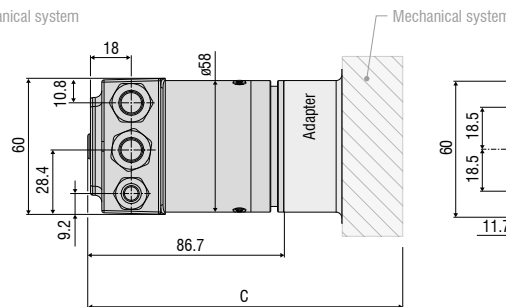
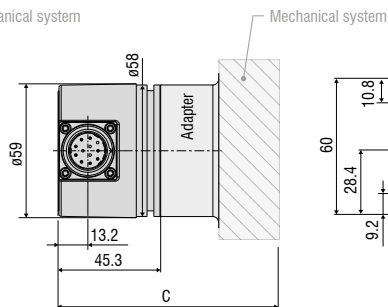
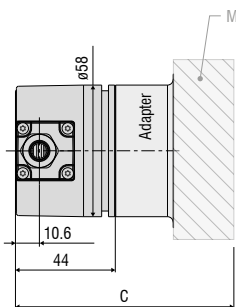

All dimensions in mm, not to scale

Total length mechanics + Encoder (C)					
Output	HTL/TTL	SSI	CO/PB	PN/ENIP/CAT	
C (mm)	MR 30,000	337.7	339.0	380.4	340.6
	MR 40,000	369.7	371.0	412.4	372.6
	MR 50,000	403.2	404.5	445.9	406.1

Model	WDS-30000-P200	WDS-40000-P200	WDS-50000-P200
Measuring range	30000 mm	40000 mm	50000 mm
Digital interface ¹⁾	PROFINET, Profibus DP, CANopen, EtherNet/IP, EtherCAT		
Digital output ¹⁾	HTL, TTL, SSI		
Resolution	HTL, TTL	0.167 mm (6 pulses/mm)	
	SSI, PROFINET, Profibus DP, CANopen, EtherNet/IP, EtherCAT	0.061 mm	
Linearity	≤ ±0.01% FSO	≤ ±3 mm	≤ ±5 mm
Sensor element	Incremental/absolute encoder		
Wire extension force (max.)	approx. 22 N	approx. 22 N	approx. 24 N
Wire retraction force (min.)	approx. 12 N	approx. 11 N	approx. 11 N
Wire acceleration (max.)	approx. 2 g		
Material	Housing	Aluminum	
	Measuring wire	Polyamide-coated stainless steel (ø 0.8 mm)	
Wire mounting	Eyelet (ø 20.2 mm)		
Installation	Mounting grooves on the sensor housing		
Temperature range	Storage	-20 ... +80 °C	
	Operation	-20 ... +80 °C	
Connection	HTL, TTL	integrated cable, radial, length 1 m	
	SSI	12-pin flange connector, radial	
	PROFINET, Profibus DP, CANopen, EtherNet/IP, EtherCAT	Bus cover	
Shock (DIN EN 60068-2-27)	50 g / 10 ms in 3 axes, 1000 shocks each		
Vibration (DIN EN 60068-2-6)	20 g / 20 ... 2000 Hz in 3 axes, 10 cycles each		
Protection class (DIN EN 60529)	IP65 ²⁾		
Weight	approx. 10 kg	approx. 11 kg	approx. 12 kg

FSO = Full Scale Output

¹⁾ Specifications for digital outputs from page 59 onwards.

²⁾ With plug version only when connected

Article designation

WDS -	30000 -	P200 -	CR -	TTL
				Output: HTL TTL CO: CANopen PB: Profibus DP SSI: Gray Code PN: PROFINET ENIP: EtherNet/IP CAT: EtherCAT
				Connection: SR (with SSI output): radial plug CR (with HTL, TTL output): integrated cable, radial, 1 m BH (with CO, PB, PN, ENIP, CAT output): bus cover
				P200 series
				Measuring range in mm

Miniature draw-wire sensors for test applications

wireSENSOR MT

Miniature sensor size

Ideal for extremely high accelerations

Easy, fast and flexible mounting

Potentiometer Output

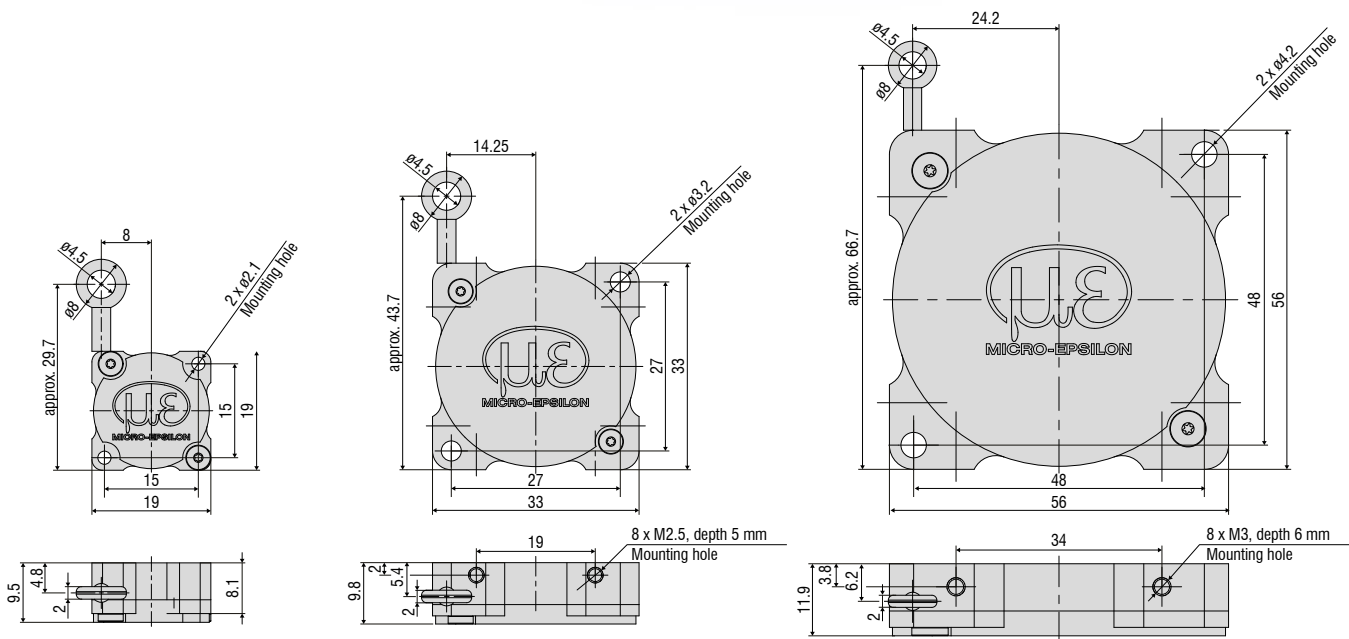

All dimensions in mm, not to scale

Model	WDS-40-MT19-P	WDS-80-MT33-P	WDS-130-MT56-P
Measuring range	40 mm	80 mm	130 mm
Analog output ¹⁾	Potentiometer		
Resolution	towards infinity		
Linearity	≤ ±0.4% FSO	-	≤ ±0.32 mm
	≤ ±1% FSO	≤ ±0.4 mm	-
Sensor element	Conductive plastic potentiometer		
Wire extension force (max.)	approx. 2 N	approx. 1.5 N	approx. 1 N
Wire retraction force (min.)	approx. 0.7 N	approx. 0.5 N	approx. 0.3 N
Wire acceleration (max.)	approx. 60 g	approx. 60 g	approx. 15 g
Material	Housing	Aluminum	
	Measuring wire	Polyamide-coated stainless steel (ø 0.36)	Polyamide-coated stainless steel (ø 0.45)
Wire mounting	Eyelet (ø 4.5 mm)		
Installation	Through-holes ø 2.1 mm	Through-holes ø 3.2 mm	Through-holes ø 4.2 mm
Temperature range	Storage	-40 ... +85 °C	
	Operation	-40 ... +85 °C	
Connection	Stranded wires, approx. 6 cm		
Shock (DIN EN 60068-2-27)	50 g / 10 ms in 1 direction, 1000 shocks		
Vibration (DIN EN 60068-2-6)	20 g / 20 ... 2000 Hz in 3 axes, 10 cycles each		
Protection class (DIN EN 60529)	IP50		
Weight	approx. 8 g	approx. 22 g	approx. 82 g

FSO = Full Scale Output

¹⁾ Specifications for analog outputs from page 58 onwards.

Article designation

WDS -	40 -	MT -	P
			Output type: P: potentiometer
		MT series	
	Measuring range in mm		

Robust miniature draw-wire sensors

wire**SENSOR** MPM analog

Compact miniature design

Flexible mounting options due to swiveling mounting flange

For very fast measurement movements, wire accelerations up to 100 g

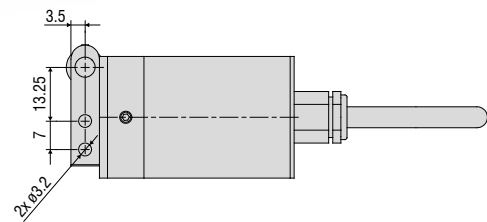
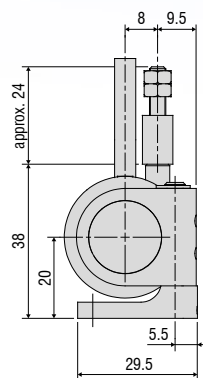
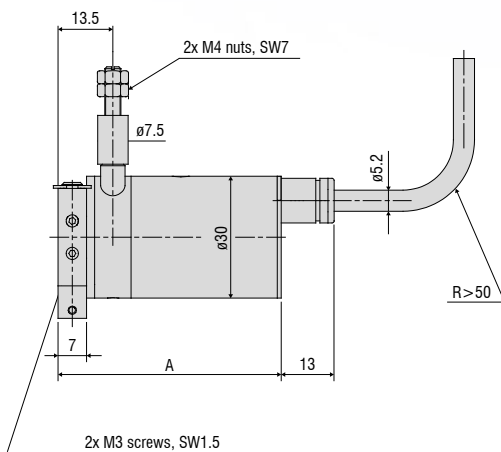

Measuring range (mm)	A (mm)
50	55
150 / 250	64
50-HG	61
150 / 250-HG	70

All dimensions in mm, not to scale

Model		WDS-50-MPM	WDS-150-MPM	WDS-250-MPM
Measuring range		50 mm	150 mm	250 mm
Analog output ¹⁾		Potentiometer		
Resolution		towards infinity		
Linearity	Conductive plastic potentiometer P20 ≤ ±0.2% FSO	≤ ±0.125 mm	-	-
	Hybrid potentiometer P25 ≤ ±0.25% FSO	-	≤ ±0.3 mm	≤ ±0.5 mm
Sensor element		Conductive plastic potentiometer	Hybrid potentiometer	
Wire extension force (max.)		approx. 3.5 N (HG option: 17 N)		
Wire retraction force (min.)		approx. 1.5 N (HG option: 10 N)		
Wire acceleration (max.)		approx. 25 g (HG option: 100 g)		
Material	Housing	Aluminum		
	Measuring wire	Stainless steel (ø 0.45 mm)		
Wire mounting		M4 threaded bolts		
Installation		Mounting flange rotatable in two axes 180° / 360°		
Temperature range	Storage	-20 ... +80 °C		
	Operation	-20 ... +80 °C		
Connection		integrated cable, axial, length 1 m		
Shock (DIN EN 60068-2-27)		50 g / 20 ms in 3 axes, 1000 shocks each		
Vibration (DIN EN 60068-2-6)		20 g / 20 ... 2000 Hz in 3 axes, 10 cycles each		
Protection class (DIN EN 60529)		IP65		
Weight		approx. 150 g (incl. cable)		

FSO = Full Scale Output

¹⁾ Specifications for analog outputs from page 58 onwards.

Article designation

WDS -	50 -	MPM -	C -	P -	HG
					HG option: wire acceleration up to 100 g
					Output type: P: potentiometer
					Connection: C: integrated cable, axial, 1 m
					MPM series
					Measuring range in mm

Robust miniature draw-wire sensors

wire**SENSOR** MP / MPW analog

Miniature design

High protection class IP67 (MPW)

For fast movements and harsh application environments

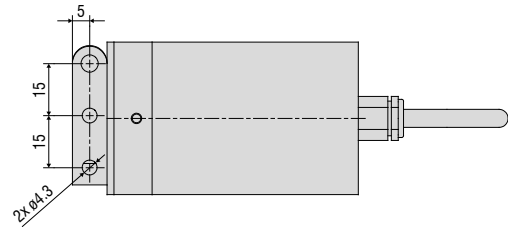
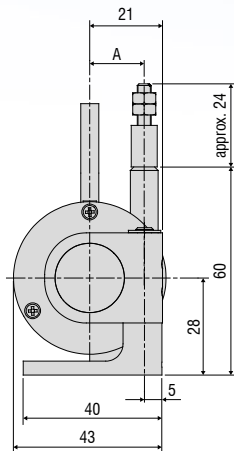
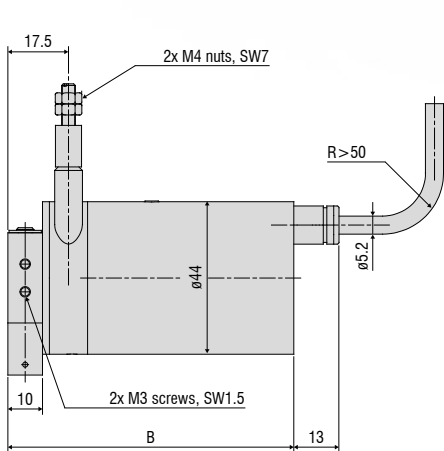

All dimensions in mm, not to scale

Measuring range (mm)	A (mm)	B (mm)
100 / 300 / 500 / 1000-MP	15.7	82.5
100 / 300 / 500 / 1000-MPW	15.7	86.5

Model	WDS-100-MP(W)	WDS-300-MP(W)	WDS-500-MP(W)	WDS-1000-MP(W)
Measuring range	100 mm	300 mm	500 mm	1000 mm
Analog output ¹⁾	Potentiometer			
Resolution	0.15 mm	0.2 mm	towards infinity	
Linearity	Hybrid potentiometer P10 ≤ ±0.1% FSO	-	-	≤ ±0.5 mm
	Wire potentiometer P25 ≤ ±0.25% FSO	-	≤ ±0.75 mm	-
	Wire potentiometer P50 ≤ ±0.5% FSO	≤ ±0.5 mm	-	-
Sensor element	Wire potentiometer		Hybrid potentiometer	
Wire extension force (max.)	approx. 8.5 N	approx. 8.5 N	approx. 8.5 N	approx. 8 N
Wire retraction force (min.)	approx. 7 N	approx. 7 N	approx. 6.5 N	approx. 5 N
Wire acceleration (max.)	approx. 30 g			
Material	Housing	Aluminum		
	Measuring wire	Stainless steel (ø 0.45 mm)		
Wire mounting	M4 threaded bolts			
Installation	Mounting flange rotatable in two axes 180° / 360°			
Temperature range	Storage	-20 ... +80 °C		
	Operation	-20 ... +80 °C		
Connection	integrated cable, axial, length 1 m			
Shock (DIN EN 60068-2-27)	50 g / 20 ms in 3 axes, 1000 shocks each			
Vibration (DIN EN 60068-2-6)	20 g / 20 ... 2000 Hz in 3 axes, 10 cycles each			
Protection class (DIN EN 60529)	MP series	IP65		
	MPW series	IP67		
Weight	approx. 270 g (incl. cable)			

FSO = Full Scale Output

¹⁾ Specifications for analog outputs from page 58 onwards.

Article designation

WDS -	100 -	MP -	C -	P
				Output type: P: potentiometer
				Connection C: integrated cable, axial, 1 m
				MP / MPW series (IP67)
				Measuring range in mm

Options

wireSENSOR

Customer-specific modifications for your series application

If the standard models do not meet certain specific requirements, draw-wire sensors from the standard range can be adapted accordingly by Micro-Epsilon. Cost-effective implementation can already be achieved with medium-sized quantities (depending on the type and number of changes).

Wire attachment

- Wire clip
- Eyelet
- Thread
- Wire extension

Measuring wire

- Plastics
- Stainless steel (coated/uncoated)
- Different diameters
- Thicker wire for improved snap protection



Connection/Output signal

- Different cable lengths
- Different plug variants
- Redundant sensor element
- Adaption of supply voltage
- Inverted signal
- Redundant signal outputs
- Alignment cable/connector outlet





Sensor mounting

- Mounting bracket
- Mounting plate
- Magnetic holder

Wire guide

- Wire wiper
- Different designs of integrated deflection pulleys
- Wire outlet socket from ceramics for increased diagonal pull up to 15°

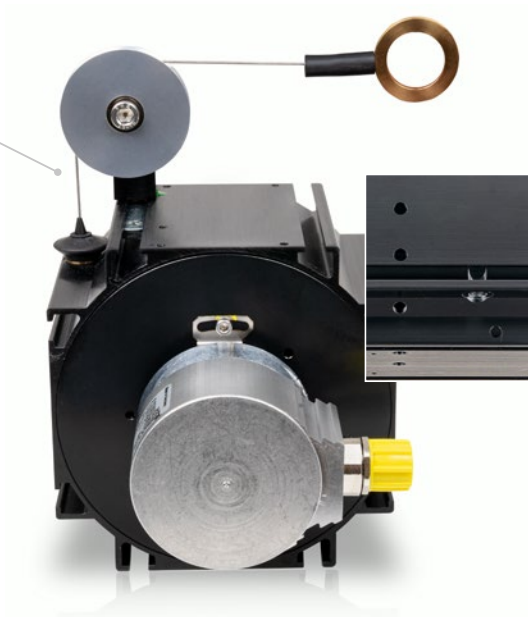

Housing and environment

- Wire outlet right (standard) / left
- Protection class up to IP69K
- Drainage holes
- Stainless steel spring
- Housing material
- Wire acceleration
- Snap protection

* Some options cannot be combined with each other; availability of options on request

Accessories

wireSENSOR

Wire deflection pulleys for external installation

TR1-WDS

Wire deflection pulley, adjustable, for sensors with a wire diameter ≤ 0.45 mm

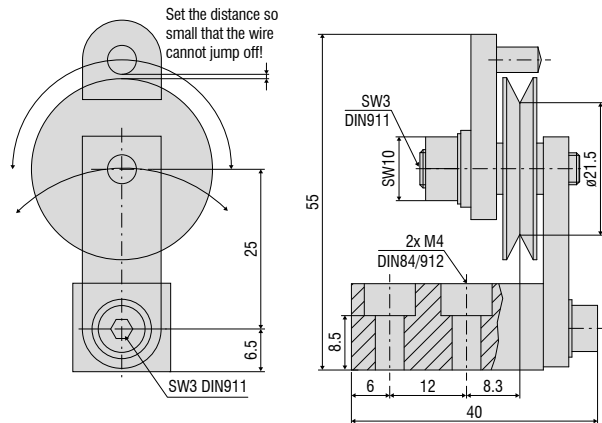

TR3-WDS

Wire deflection pulley, fixed, for sensors with a wire diameter ≤ 0.45 mm

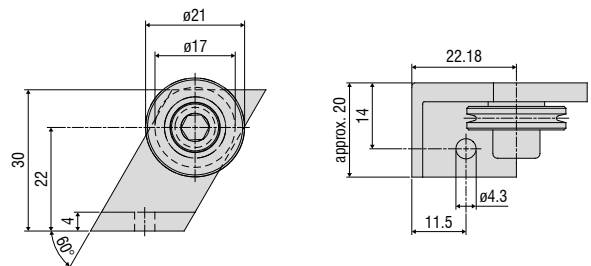

TR4-WDS

Wire deflection pulley, fixed, for sensors with a wire diameter of 0.8 mm to 1 mm

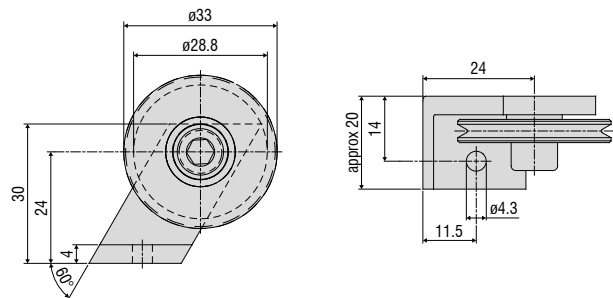

Wire deflection pulley for direct installation on the sensor housing

TR5-WDS

Integrated wire deflection pulley for P115 sensors with a wire diameter of 0.45 mm

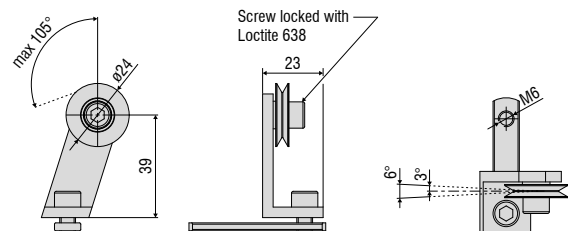

All dimensions in mm, not to scale

TR5-WDS(03)

Integrated double deflection pulley for P115 sensors with a wire diameter of 0.45 mm

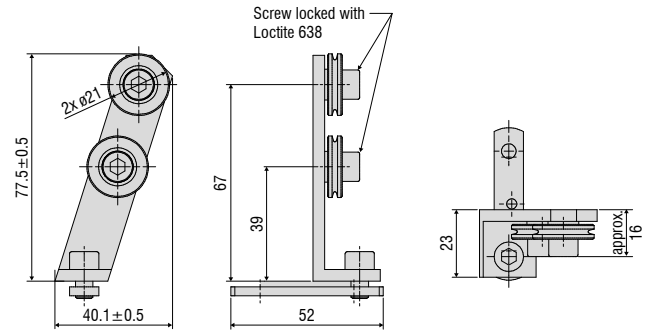

TR5-WDS(04)

Integrated double deflection pulley, 90° angled, for P115 sensors with a wire diameter of 0.45 mm

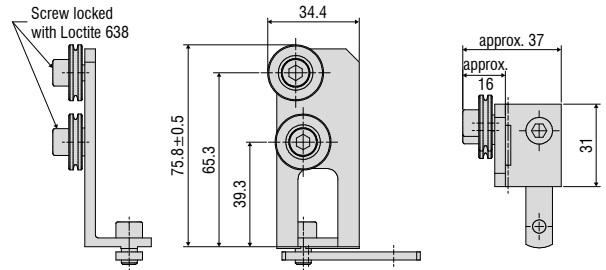

TR6-WDS(01)

Integrated wire deflection pulley for the P115 sensors with a wire diameter of 1 mm

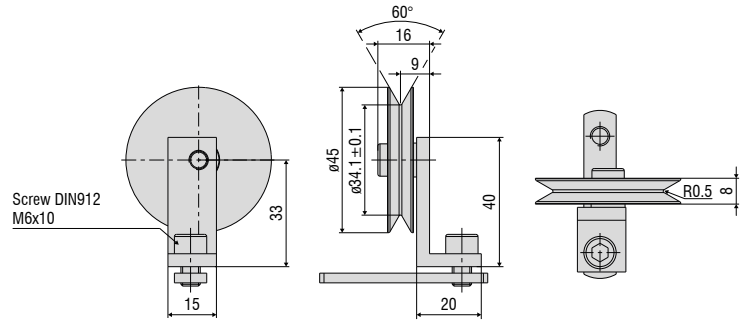

Mounting bracket set

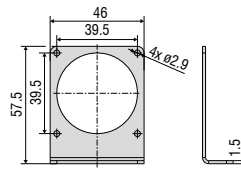

WPS-MB46
for the MK46 series
(Output types: P10/P25/E/E830)

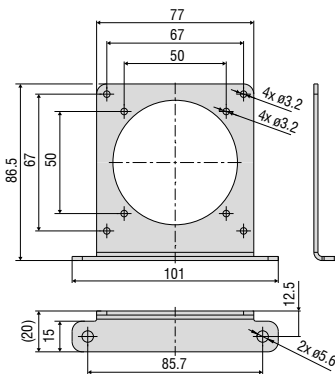

WPS-MB77
for the MK77 series

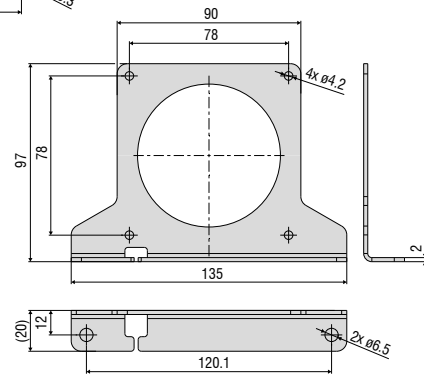

WPS-MB88
for the MK88 series

Accessories & Notes for installation

wireSENSOR

Accessories

WE-xxx-M4	Wire extension with M4 wire connection, x=wire length
WE-xxx-Clip	Wire extension with eyelet, x = wire length
WE-xxx-Clip-WSS	Wire extension with clip and uncoated wire d=0.45 mm
WE-xxx-Ring-PW	Wire extension with plastic ring and para-aramid wire, 1 mm
GK1-WDS	Fork head for M4
MH1-WDS	Magnetic holder for wire attachment
MH2-WDS	Magnetic holder for sensor mounting
MT-60-WDS	Mounting clamps for WDS-P60
FC8	Mating plug for WDS straight, 8-pin
FC8/90	Mating plug, 90° angled for WDS
PC3/8-WDS	Sensor cable, 3 m long, for WDS with 8-pin cable connector
WDS-MP60	Mounting plate for P60 models
WPS-MB46	Mounting bracket set for the MK46 series (output type: P10/P25/E/E830)
WPS-MB77	Mounting bracket set for the MK77 series
WPS-MB88	Mounting bracket set for the MK88 series
PC2/10-WDS-A	Cable for SSI encoder, 2 m long
PC10/10-WDS-A	Cable for SSI encoder, 10 m long
PC5/5-IWT	Sensor cable, 5 m long, M12x1 connector, 5-pin, A-coding

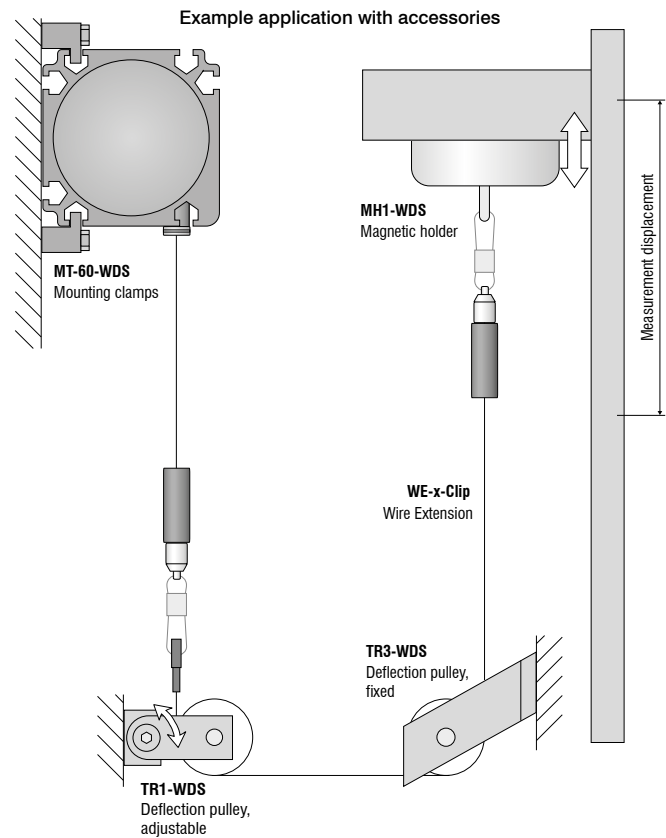

WDS-MP60

Mounting plate for P60 models

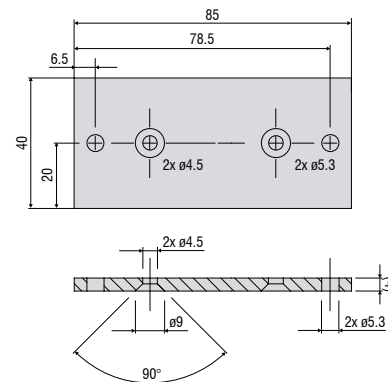

All dimensions in mm, not to scale

Installation instructions:

Wire attachment: during installation, do not allow at any time the measuring wire to freely return.

Angle of wire outlet: Make sure during installation that the wire outlet is straight (tolerance of $\pm 3^\circ$). Exceeding this tolerance leads to increased wear of the wire material and on the wire outlet.

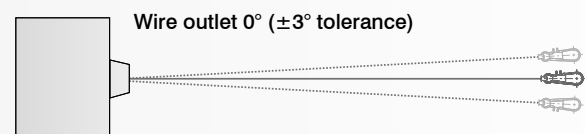

WE-xxx-M4

Wire extension with M4 wire connection, x=wire length

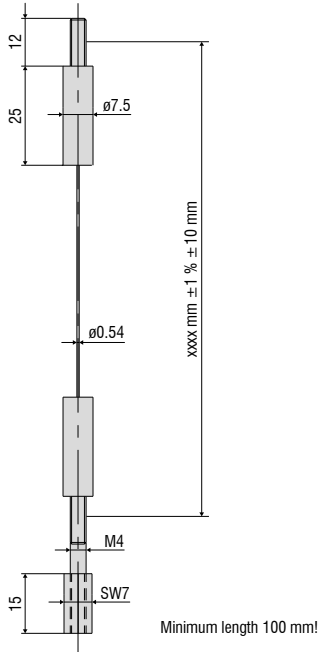

WE-xxx-Clip

Wire extension with eyelet, x = wire length

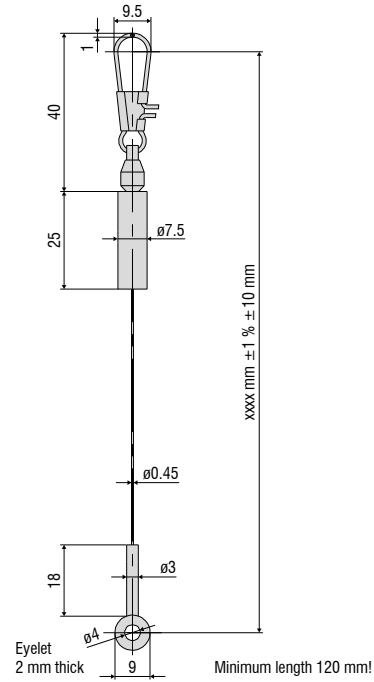

MH1-WDS

Magnetic holder for wire attachment

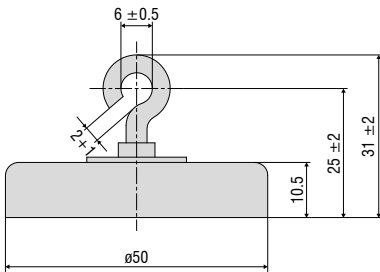

MH2-WDS

Magnetic holder for sensor mounting

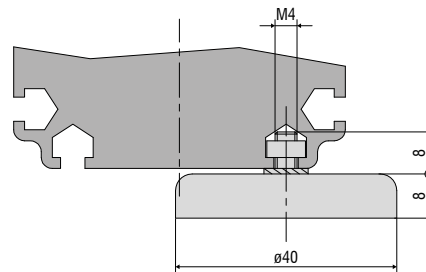

GK1-WDS

Fork head for M4

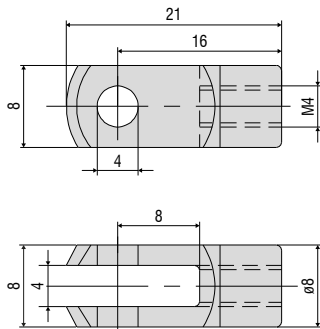

MT-60-WDS

Mounting clamps for WDS-P60

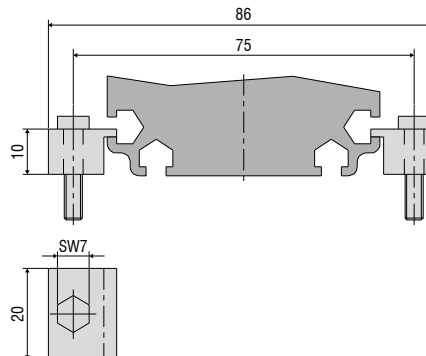

Output specifications

wireSENSOR

Analog

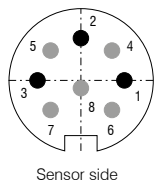
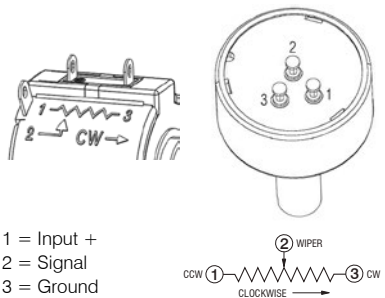
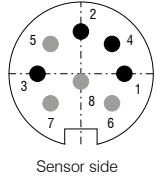
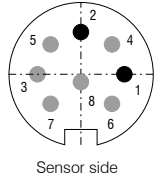
Output		Connector M16 -SA / -SR	Integrated cable -CA / -CR	Open contacts
Potentiometer output (P)		 <p>Sensor side</p> <p>1 = Input + 2 = Ground 3 = Signal</p>	<p>White = Input + Brown = Ground Green = Signal</p>	 <p>1 = Input + 2 = Signal 3 = Ground</p> <p>② WIPER CLOCKWISE →</p>
Input voltage	max. 32 VDC with 1 kOhm / max. 1 W			
Resistance	1 kOhm ± 10 % (resistance divider)			
Temperature coefficient	±0.0025 % FSO/°C			
Voltage output (U)		 <p>Sensor side</p> <p>1 = Power supply 2 = Ground 3 = Signal 4 = Ground</p>	<p>White = Supply Brown = Ground Green = Signal Yellow = Ground</p>	
Supply voltage	14 ... 27 VDC (non-stabilized)			
Current consumption	max. 30 mA			
Output voltage	0 ... 10 VDC Option 0 ... 5 / ±5 V			
Load resistance	>5 kOhm			
Output noise	0.5 mV _{eff}			
Temperature coefficient	±0.005 % FSO/°C			
Electromagnetic compatibility (EMC)	EN 61000-6-4 EN 61000-6-2			
Adjustment range (if supported by the model)				
Zero	±20 % FSO			
Sensitivity	±20 %			
Current output (I)		 <p>Sensor side</p> <p>1 = Power supply 2 = Ground</p>	<p>White = Supply Brown = Ground</p>	
Supply voltage	14 ... 27 VDC (non-stabilized)			
Current consumption	max. 35 mA			
Output current	4 ... 20 mA			
Load	<600 Ohm			
Output noise	<1.6 μA _{eff}			
Temperature coefficient	±0.01 % FSO/°C			
Electromagnetic compatibility (EMC)	EN 61000-6-4 EN 61000-6-2			
Adjustment range (if supported by the model)				
Zero	< ±18 % FSO			
Sensitivity	±15 %			

CANopen

(for the MK88 and K100 series)

CANopen features	
Profiles	Communication profile CiA 301. Device profile CiA 406 (absolute linear encoder)
SDO	1x SDO server
PDO	2x TxPDO
PDO modes	Event/time-triggered, synchronous (cyclic/acyclic)
Preset value	The "Preset" parameter can be used to set the current measured value to any value. The difference from the original value is stored in the object.
Direction	Via the operating parameter, the counting direction of the measured values can be reversed
Diagnosis	Heartbeat, Emergency Message
Default setting	AutoBaud(9), Node-ID 1

Setting the baud rate	
Baud rate adjustable via LSS or object 0x3001	
0	1000 kBaud
2	500 kBaud
3	250 kBaud
4	125 kBaud
6	50 kBaud
9	AutoBaud (default)

Description of the connections	
Pin	Assignment
1	n. c.
2	V+ (7...32VDC)
3	GND
4	CAN-High
5	CAN-Low



Setting the subscriber address (node ID)
Address adjustable via LSS or object 0x3000 (1....127, 1=default)

Output specifications

wireSENSOR

CANopen

(for P60, P96, P115 and P200 series)



Setting the CANopen baud rate			
Baud rate	DIP switch setting		
	1	2	3
10 kBit/s	OFF	OFF	OFF
20 kBit/s	OFF	OFF	ON
50 kBit/s	OFF	ON	OFF
125 kBit/s	OFF	ON	ON
250 kBit/s	ON	OFF	OFF (factory settings)
500 kBit/s	ON	OFF	ON
800 kBit/s	ON	ON	OFF
1 MBit/s	ON	ON	ON

If Node-ID 00 is set, the baud rate can be programmed via the CAN bus.

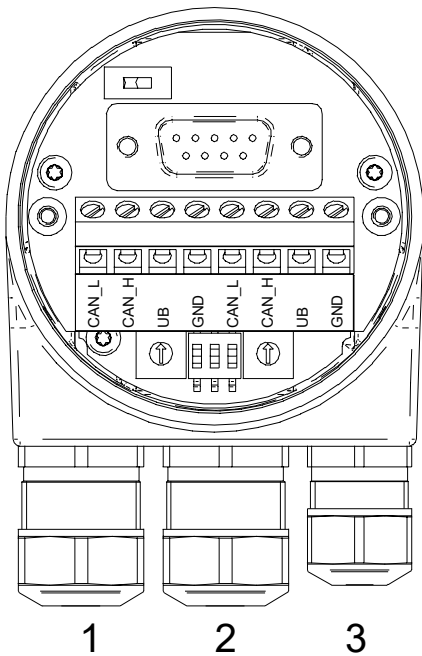

Description of the CANopen connections	
GND	Ground connection for UB
UB	Operating voltage
CAN_H	CAN bus signal (dominant High)
CAN_L	CAN bus signal (dominant Low)

Max. core cross-section	
Single-wire (rigid)	1.5 mm ²
Fine-wired (flexible)	1.0 mm ²
Fine-wired (flexible)	With ferrule 0.75 mm ²

Cable diameter	
Cable gland 1,2	ø8...10 mm (-40...+85 °C) ø5...9 mm (-25...+85 °C)
Cable gland 3	ø4.5...6 mm (-40...+85 °C) ø3...6 mm (-25...+85 °C)

Tightening torque
Terminal block/screw terminal max. 0.4 Nm (recommended tightening torque 0.3 Nm)

Settings of the CANopen participant address
Address can be set with rotary switch. Example: Participant address 23

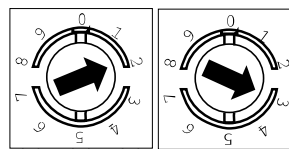

SSI (Gray Code)

Pin assignment

Flange socket M23, 12-pin, pin contacts, CW
(assignment according to option 3252)

PIN	Assignment
1	+Vs
2	0 V
3	Clock+
4	Data+
5	SET
6	Data-
7	Clock-
8	-
9	DIR
10	-
11	-
12	-

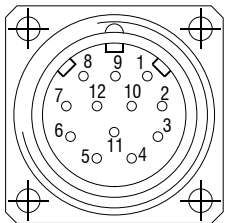

Connections

SET	<p>Zero setting input For setting a zero point at any point. The zeroing process is triggered by a High pulse and must take place after the rotating direction selection (DIR). Pulse duration > 100 ms. For maximum interference immunity, connect to 0 V after zeroing.</p>
DIR	<p>Counting direction input When not connected, this input is on High. DIR High means increasing output data with a clockwise rotating shaft when looking at the flange. DIR Low means increasing values with a counterclockwise rotating shaft when looking at the flange. For maximum interference immunity, connect to +Vs or 0 V depending on the direction of rotation.</p>

Switching level

SSI switch

SSI clock	RS422 with terminating resistance 120 Ω
SSI data	RS422

Control inputs of input circuit

Input level High	>0.7 UB
Input level Low	<0.3 UB
Input resistance	10 kΩ

Output specifications

wireSENSOR

PROFIBUS

Profibus DP features	
Bus protocol	Profibus-DPV0
Device profile	Device class 1 and 2
Cyclical data exchange	Communication in accordance with DPV0
Input data	Position value Additional configurable speed signal
Output data	Preset value
Preset value	This parameter can be used to set the rotary encoder to a desired position value that corresponds to a defined axis position of the system. The storage is non-volatile.
Rotary direction	This parameter can be used to parameterize the direction of rotation in which the position value should rise or fall.
Scaling	Parameterization of the steps per rotation and the total resolution.
Gear factor	Adjustable via counter / denominator
Diagnosis	Position and parameter errors Monitoring multi-turn scanning Readable hour meter

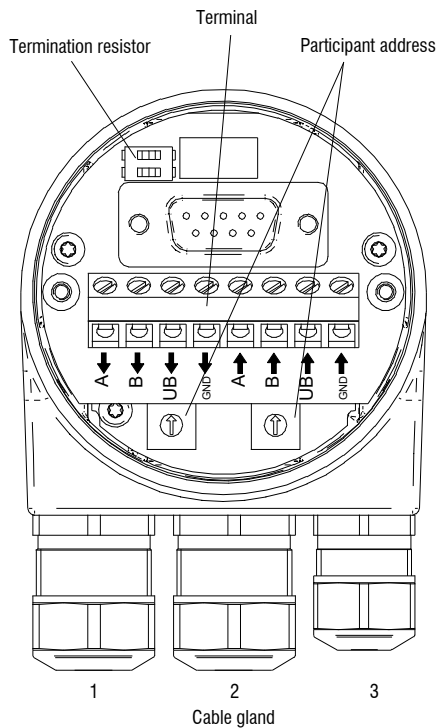

Cable: 1, 2 = \varnothing 8 - 10 mm (-40 - 85 °C) / \varnothing 5 - 9 mm (-25 - 85 °C)
 Cable: 3 = \varnothing 4.5 - 6 mm (-40 - 85 °C) / \varnothing 3 - 6 mm (-25 - 85 °C)

Pin assignment	
+Vs	Operating voltage 8...30 VDC
0 V	Ground connection related to +Vs
A	Negative data line
B	Positive data line

Terminals with the same designation are internally connected and functionally identical. These internal terminal connections Vs-Vs / 0V-0V may be loaded with max. 1 A each.

Terminator

Both ON = last participant
 Both OFF = participant X
 Default setting OFF

Participant address

Adjustable via rotary switch
 Example: Participant address 23
 Default setting: 00

PROFINET

PROFINET features	
Bus protocol	PROFINET IO
Device profile	Encoder Profile PNO 3.162 V4.1 and V3.1 PROFdrive Profil PNO 3.172 V4.1
Real-time classes	Realtime (RT) Class 1, IRT Class 3
Transmission frequency	RT: 1 ms, 2 ms, 4 ms IRT: 250 μ s, 500 μ s, 1 ms, 2 ms, 4 ms
Update time	Min. 500 μ s
Product features	<ul style="list-style-type: none"> - 100 MBaud Fast Ethernet - Device replacement without removable media - Media redundancy protocol MRP - Gear factor / round axis
Process data	<ul style="list-style-type: none"> - Position value 32-Bit input data with/without rotational speed 16 or 32 Bit - Telegram 81-83 of the PROFdrive profile
LED status display	Link/Activity, Status, Error

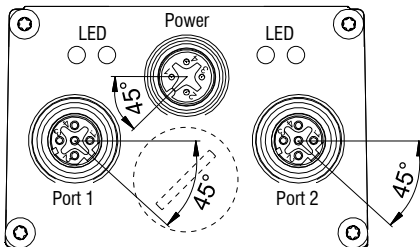

Pin Assignment

Operating voltage		
Pin	Connection	Description
1	UB	Operating voltage
2	n.c.	Do not connect
3	GND	Ground connection
4	n.c.	Do not connect

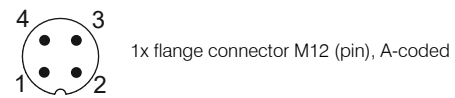

PROFINET (data line)		
Pin	Connection	Description
1	TxD+	Transmitted data+
2	RxD+	Received data+
3	TxD-	Transmitted data-
4	RxD-	Received data-

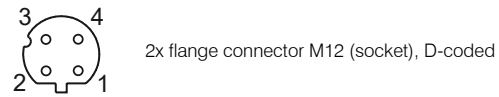

Output specifications

wireSENSOR

EtherNet/IP

EtherNet/IP characteristics

Bus protocol	EtherNet/IP
Device profile	CIP Nov 2016, 22 _{hex} Encoder
Cycle time	1 ms
Product features	<ul style="list-style-type: none"> - Gear factor (round axis) and continuous operation - Plausibility test of adjustable parameters - Comprehensive diagnosis function - Address Conflict Detection - Device Level Ring - Several simultaneous IO connections
LED status display	2x Link/Activity, module status, network status

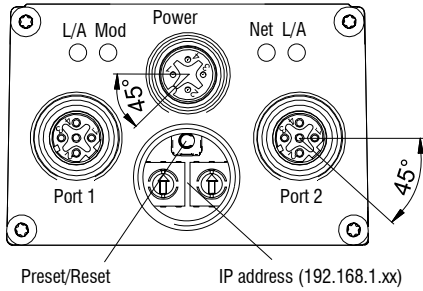

Pin Assignment

Operating voltage

Pin	Connection	Description
1	UB	Operating voltage
2	d.c.	Do not connect
3	GND	Ground connection
4	d.c.	Do not connect

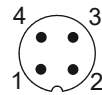

1x flange connector M12 (pin), A-coded

EtherNet/IP (data line)

Pin	Connection	Description
1	TxD+	Transmitted data+
2	RxD+	Received data+
3	TxD-	Transmitted data-
4	RxD-	Received data-

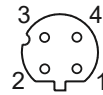

2x flange connector M12 (socket), D-coded

EtherCAT

EtherCAT characteristics	
Bus protocol	EtherCAT
Device profile	Encoder profile CANopen® CiA 406 Vers. 4.0.2 dated August 18, 2016
Operating modes	Free Run, synchronous with SM3 Event, DC Mode (Distributed Clocks)
Cycle time	Min. 62.5 μ s
Product features	<ul style="list-style-type: none"> - Gear factor (round axis) and continuous operation - Time stamp (time of position data acquisition) - Plausibility check of adjustable parameters - Comprehensive diagnosis function - Preset gauge for position - File Access over EtherCAT (FoE)
Process data	<ul style="list-style-type: none"> - Position value 32-Bit input data with/without rotational speed 32 Bit - Comprehensive process data mapping
LED status display	2x Link/Activity, RUN, ERR

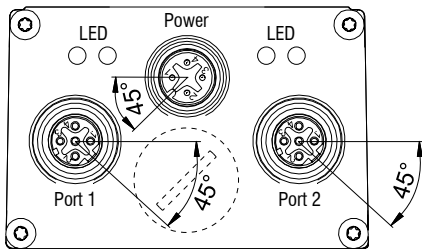

Pin Assignment

Operating voltage		
Pin	Connection	Description
1	UB	Operating voltage
2	n.c.	Do not connect
3	GND	Ground connection
4	n.c.	Do not connect

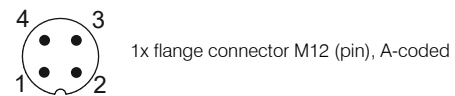

EtherCAT (data line)		
Pin	Connection	Description
1	TxD+	Transmitted data+
2	RxD+	Received data+
3	TxD-	Transmitted data-
4	RxD-	Received data-

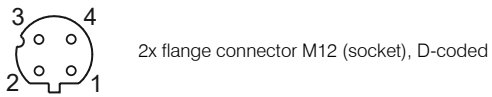

Output specifications

wireSENSOR

Incremental encoder

Output signals

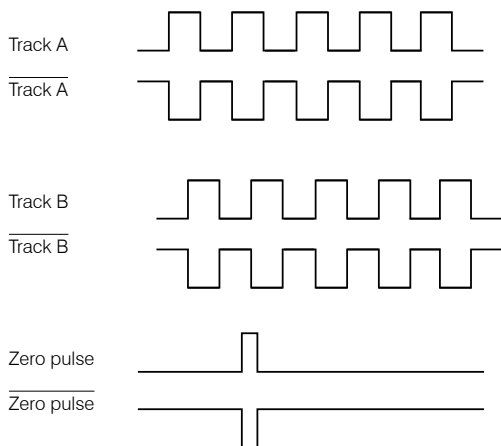

TTL Output	Line driver (5 VDC)
High level	$\geq 2.5 \text{ V}$
Low level	$\leq 0.5 \text{ V}$
High load	$\leq 20 \text{ mA}$
Tracks	A, \bar{A} , B, \bar{B} , 0

Output TTL01/ TTL02	NPN (5 VDC $\pm 5 \%$)
High level	$> 4.5 \text{ V}$
Low level	$< 1.0 \text{ V}$
High load	$\leq 3 \text{ mA}$
Tracks (TTL01)	A, B, 0
Tracks (TTL02)	A, \bar{A} , B, \bar{B} , 0

Output HTL	Push-pull (10 ... 30 VDC)
High level	$\geq V+ -3 \text{ V}$
Low level	$\leq 1.5 \text{ V}$
High load	$\leq 40 \text{ mA}$
Tracks	A, \bar{A} , B, \bar{B} , 0

Output E	Push-pull (5 VDC)
High level	$\geq V+ -2.5 \text{ V}$
Low level	$\leq 0.5 \text{ V}$
High load	$\leq 50 \text{ mA}$
Tracks	A, B, 0

Output E830	Push-pull (8 ... 30 VDC)
High level	$\geq V+ -3 \text{ V}$
Low level	$\leq 2.5 \text{ V}$
High load	$\leq 50 \text{ mA}$
Tracks	A, B, 0

Pin assignment TTL, HTL		
Connector	Cable color	Assignment
Pin 1	pink	B-
Pin 2	-	-
Pin 3	blue	R+
Pin 4	red	R-
Pin 5	green	A+
Pin 6	yellow	A-
Pin 7	-	-
Pin 8	gray	B+
Pin 9	-	-
Pin 10	white	GND
Pin 11	-	-
Pin 12	brown	UB

Pin assignment E, E830	
Cable color	Assignment
white	0 V
brown	V+
green	A
-	\bar{A}
yellow	B
-	\bar{B}
gray	0

Pin assignment TTL01	
Cable color	Assignment
brown	0 V
gray	V+
white	A
green	B
yellow	0

Pin assignment TTL02	
Cable color	Assignment
red	V+
black	0 V
brown	A
black	\bar{A}
orange	B
black	\bar{B}
yellow	0
black	n. c.

Sensors and Systems from Micro-Epsilon



Sensors and systems for displacement, distance and position



Sensors and measurement devices for non-contact temperature measurement

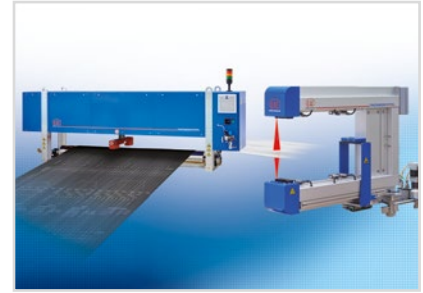

Measuring and inspection systems for metal strips, plastics and rubber

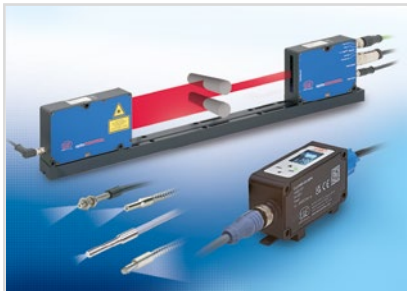

Optical micrometers and fiber optics, measuring and test amplifiers



Color recognition sensors, LED analyzers and inline color spectrometers



3D measurement technology for dimensional testing and surface inspection