



More Precision

scanCONTROL // 2D/3D Laser profile sensors



New products
scanCONTROL

```
...use_y = False  
...use_z = False  
...operation = "MIRROR_Y":  
...use_x = False  
...use_y = True  
...use_z = False  
...operation = "MIRROR_Z":  
...use_x = False  
...use_y = False  
...use_z = True  
  
...selection at the end -add back the best  
...ob.select= 1  
...ob.select=1  
...context.scene.objects.active = modifier_ob  
...selected" + str(modifier_ob) + modifier_ob  
...ob.select = 1  
...try:context.selected_objects[0]  
...objects[one.name].select= 1  
...print("please select exist in the scene")  
...operator
```

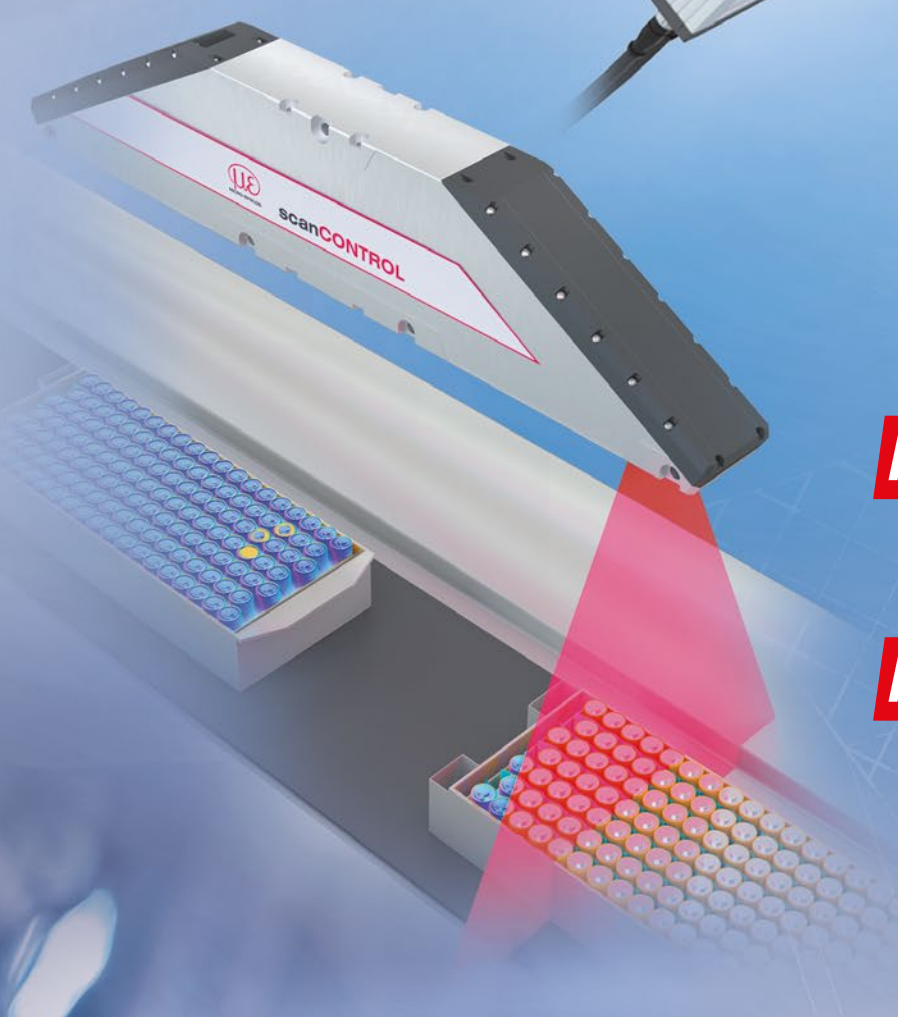

NEW

scanCONTROL 30xx
Large measuring range
with 430 and 600 mm

NEW

3D Profile Unit
Profile calculation of up to
8 laser scanners

Contents

Content / Model	Description	Page
scanCONTROL	Advantages and special features	4 - 5
scanCONTROL	Measuring principle Software features	6 - 7
scanCONTROL	All products at a glance Measurement areas	8 - 9
scanCONTROL	Application examples	10 - 11
scanCONTROL 25x0	Laser scanner for industrial series applications <ul style="list-style-type: none"> ▪ Technical data ▪ Dimensions and measuring ranges 	12 - 13 16 - 19
scanCONTROL 29x0	Compact laser scanner with high precision <ul style="list-style-type: none"> ▪ Technical data ▪ Dimensions and measuring ranges 	14 - 15 16 - 19
scanCONTROL 30x2	Powerful 2D/3D laser scanners <ul style="list-style-type: none"> ▪ Technical data ▪ Dimensions and measuring ranges 	20 - 21 22 - 23 29 - 33
scanCONTROL 30x0	Powerful 2D/3D laser scanners with highest precision <ul style="list-style-type: none"> ▪ Technical data ▪ Dimensions and measuring ranges 	24 - 25 26 - 27 29 - 33
Software	<ul style="list-style-type: none"> ▪ scanCONTROL Configuration Tools / Configuration ▪ scanCONTROL 3DInspect 	34 - 35 36 - 37
Integration of scanCONTROL	Interfaces for parameter settings and data transfer functions Ethernet and GigE Vision, C++, LabVIEW, Linux, Cognex VisionPro	38 - 39
System for multi-scanner applications	3D Profile Unit – Controller for profile calculation	40 - 41
Accessories	<ul style="list-style-type: none"> ▪ 2D/3D Gateway ▪ 2D/3D Output Unit ▪ Protection and cooling housings ▪ Connection cables 	42 43 44 - 45 46
3D sensors for shape and surface measurements	<ul style="list-style-type: none"> ▪ surfaceCONTROL 3D 3500 ▪ reflectCONTROL 	47

Advantages and special features

scanCONTROL

Compact size and integrated evaluation without external controller or IPC

High profile resolution for the detection of finest details

High profile rate for dynamic measurement tasks

Made / Developed in Germany

Numerous references worldwide

Proven high operational safety in the 24/7 operation over many years

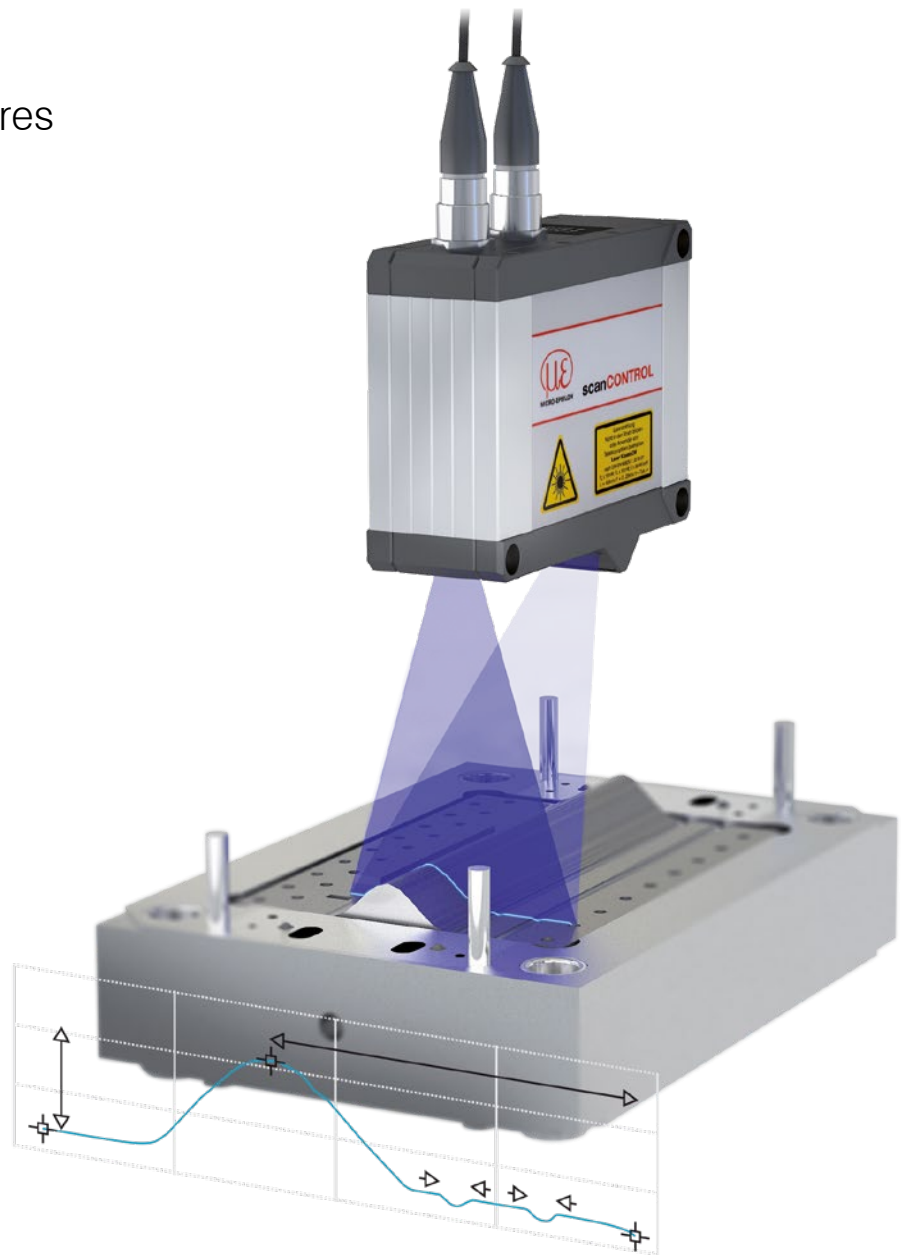

Compact. Powerful. Integrable.

Laser profile scanners from Micro-Epsilon are among the highest performing profile sensors with respect to accuracy and measuring rate. Equipped with powerful processors and highly sensitive optical components, these scanners ensure precise profile measurements on almost any type of surface.

While they can be integrated in various environments, the scanners also impress with their compact design which includes an integrated controller.

Universal Application

- Comprehensive scanner portfolio for transmission of profiles or measured values in industrial measurement tasks
- 2D inline measurement of different parameters (gap, step, radius, circle)
- 3D data and images for image processing
- Also suitable for robots & multi-sensor applications

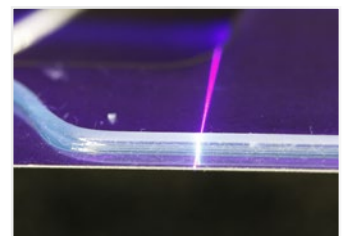
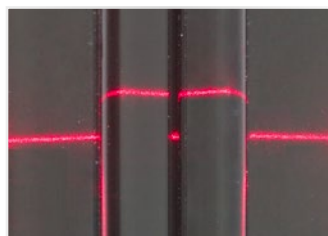
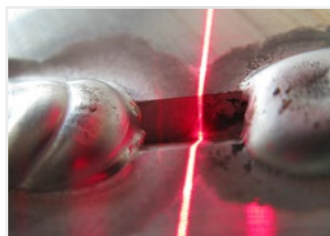

Integrated Controller for Direct Processing

scanCONTROL laser scanners have an integrated controller and therefore do not require any external control unit. This considerably simplifies wiring and their integration into restricted spaces or on a robot. The available interfaces allow the scanners to be integrated in industrial environments. For multi-scanner applications, interface modules are available.



Real Time Surface Compensation

Dynamic adaption to rapidly changing surfaces

Laser profile scanners use diffusely reflected laser light of which the intensity is highly dependent on the color and how shiny and reflective the respective component is. In order to be able to measure reliably under rapidly changing conditions, scanCONTROL sensors offer the Real-Time-Surface-Compensation feature. Due to this smart feature, the exposure time and the threshold of reflection detection are adapted in real time in order to generate stable measurement results. Moreover, the scanCONTROL 3000 series comes with an HDR function which ensures accurate detection of inhomogeneous surfaces.

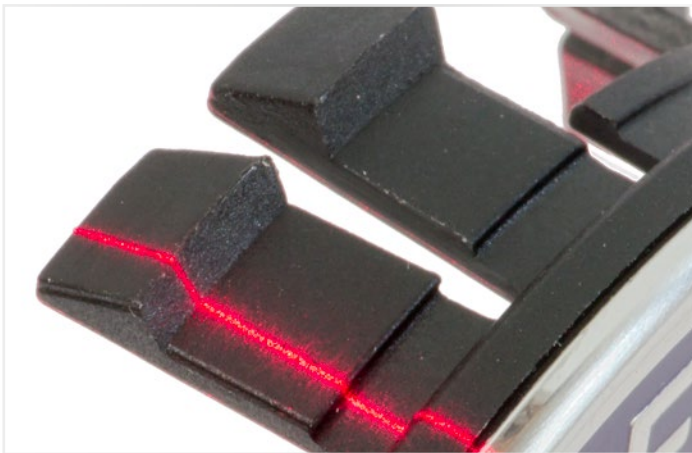
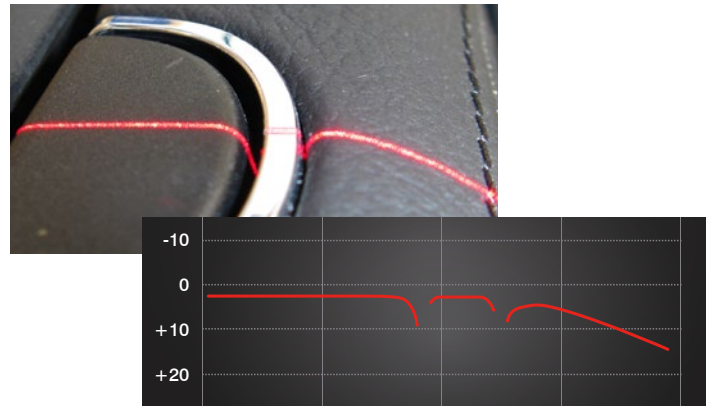

Red and Blue Laser

Laser scanners from Micro-Epsilon are available with red and blue laser. For common measurement tasks, scanCONTROL laser scanners with red laser line are used. With objects into which the laser light penetrates, such as transparent or organic surfaces, blue laser scanners are recommended. Blue Laser scanners are also ideal for red-hot glowing metals.

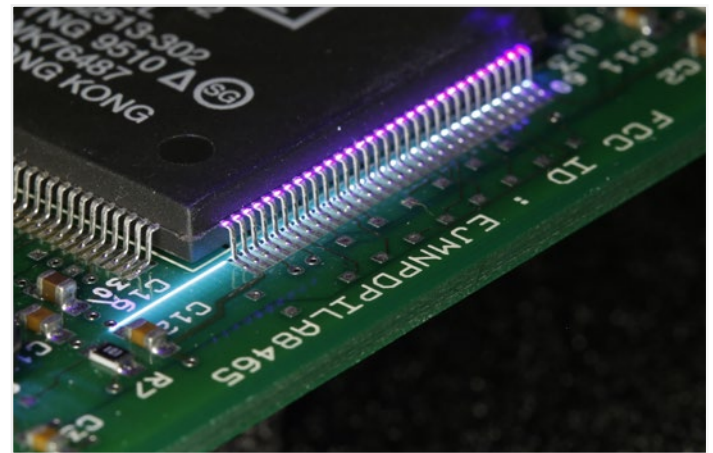

Patent Protection

for red-hot glowing and transparent objects

The internationally patented measurement methods for Blue Laser Technology allow precise measurements to be made on transparent or red-hot glowing objects above 700 °C.

Transparent objects include plastics, glass, adhesives, silicones, paints, coatings, Plexiglas and seals. Any questions about Blue Laser scanners? We will be pleased to advise you.

Measuring principle scanCONTROL

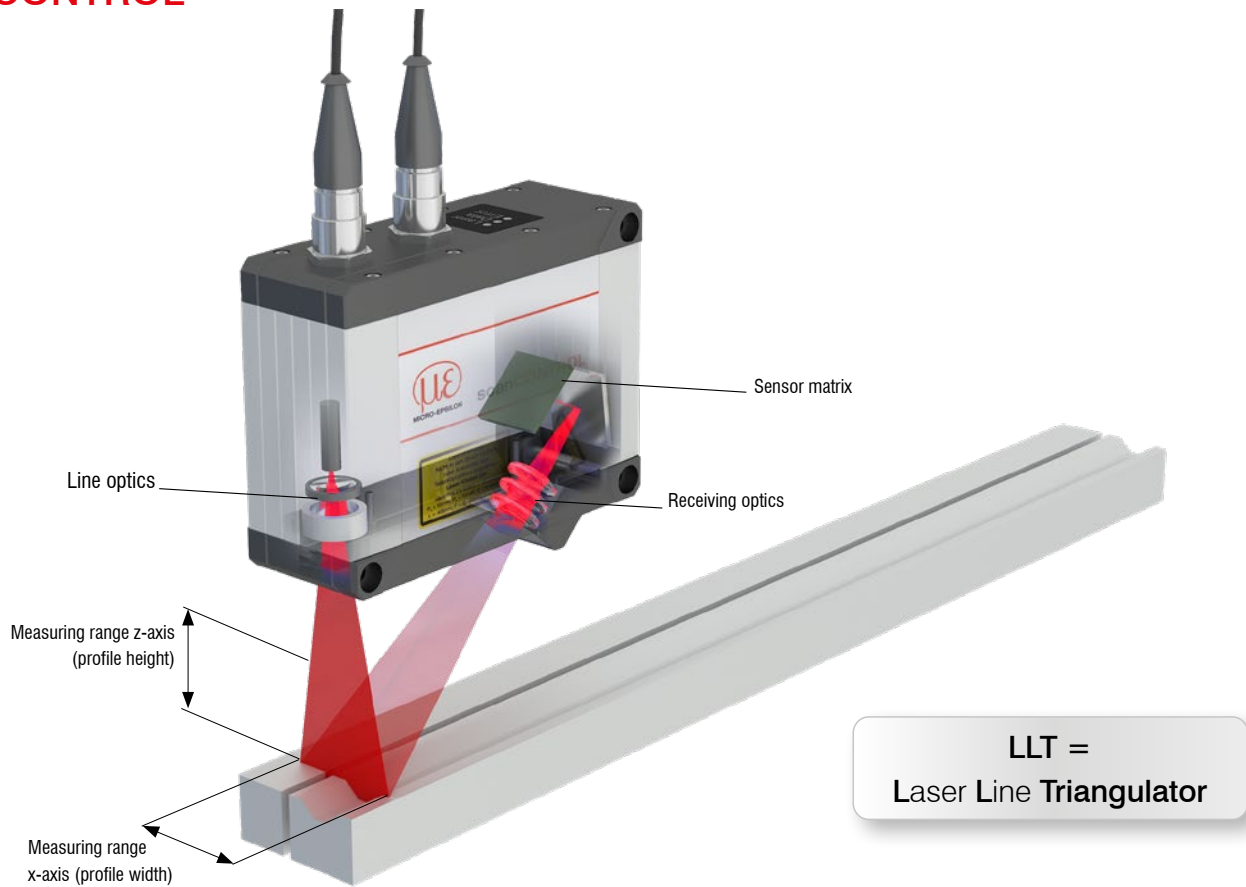

The principle of laser line triangulation

Laser scanners – often referred to as profile sensors – use the laser triangulation principle for two-dimensional profile detection on different target surfaces. By using special lenses, a laser beam is enlarged to form a static laser line and is projected onto the target surface. The receiving optics projects the diffusely reflected light of this laser line onto a highly sensitive sensor matrix. In addition to distance information (z-axis), the controller also uses this camera image to calculate the position along the laser line (x-axis). These measured values are subsequently output in a two-dimensional coordinate system that is fixed with respect to the sensor. In the case of moving objects or a traversing sensor, it is therefore possible to obtain 3D measurement values.

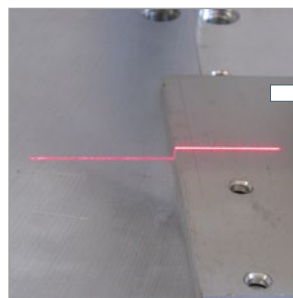

Laser line
Projecting a laser line onto the target surface

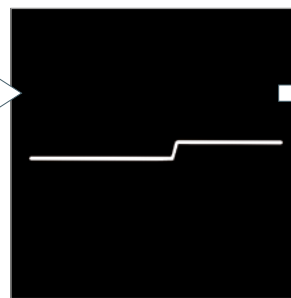

Sensor matrix (pixels)
Diffuse reflected light of the laser line is registered by a high quality sensor array

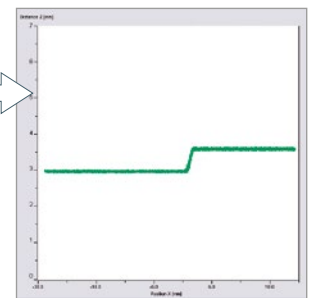

Calibrated x/z measuring points
Calculation of the distance coordinate z and the actual position x along the laser line for each measuring point

Software features

scanCONTROL

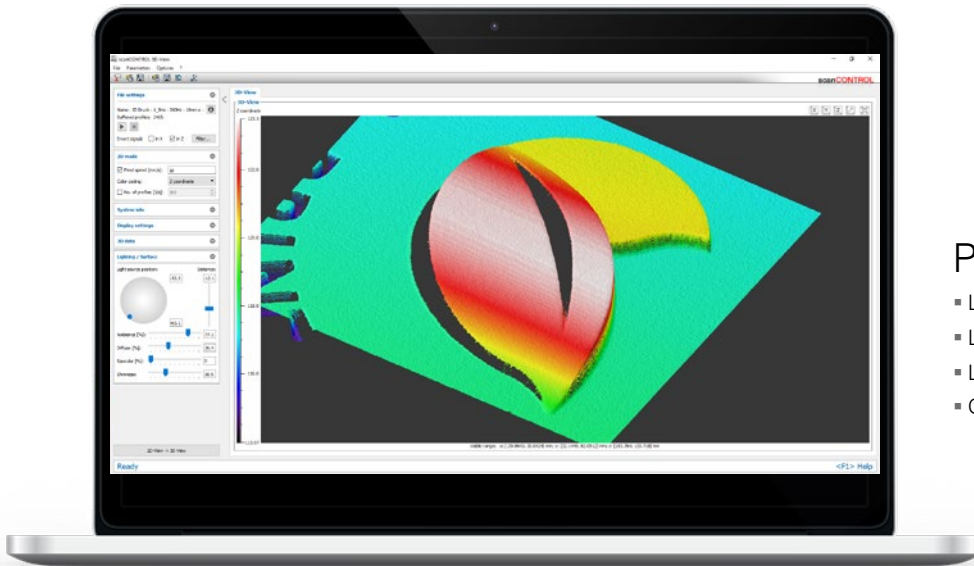

Powerful SDKs

- Libraries for C, C++, C# and VB
- LabVIEW driver
- Linux implementation
- Cognex VisionPro

Powerful Software

The scanCONTROL Configuration Tools software offers numerous measuring programs with a total of 94 evaluation variants. This is how all important profile measurement tasks can be set up and combined.

- User-friendly parameter software for all scanCONTROL SMART models
- Analysis and evaluation directly in the sensor

The 3DInspect software is a powerful tool for sensor parameter set up and industrial measurement tasks.

- Compatible with all 3D sensors from Micro-Epsilon
- Intuitive user interface
- Real 3D evaluation
- Object extraction in 3D

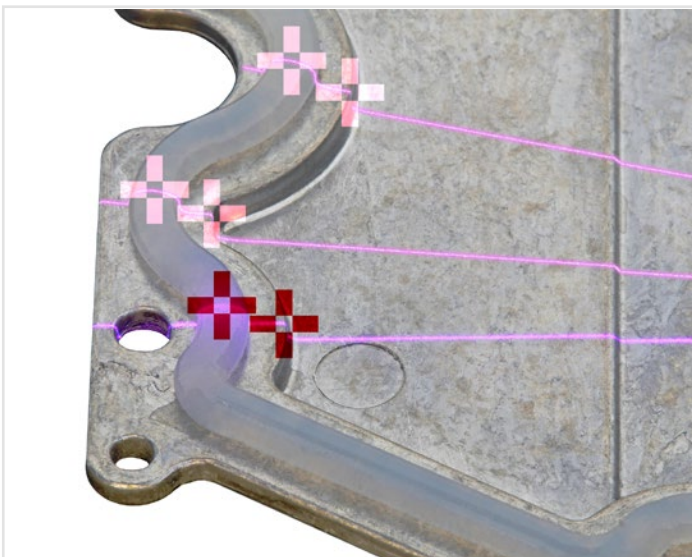

Intelligent Tracking

scanCONTROL SMART sensors can be used to track complex structures and to guide robots. Therefore, anchor points are set in the Configuration Tools software which are used to track and measure the profiles.

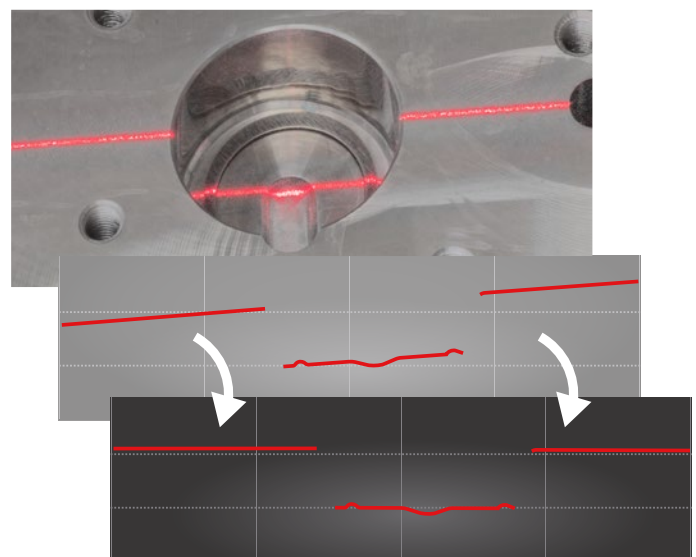





Profile Correction

With obliquely detected profiles, the Configuration Tools software corrects the inclination and therefore simplifies the sensor alignment.

All products at a glance

scanCONTROL

	PROFILE	SMART
	Evaluation by customer The PROFILE models provide calibrated profile data that can be further processed on a PC with software evaluation provided by the customer.	Integrated evaluation The SMART models provide selected measurement values . The parameter setup for the sensors and the measurement programs are stored in the internal controller.
 <p>LLT25x0 640 points/profile Profile frequency up to 2000 Hz Red laser / blue laser</p>	<p>scanCONTROL 2500</p>	<p>scanCONTROL 2510</p>
 <p>LLT29x0 1280 points/profile Profile frequency Standard up to 300 Hz High speed up to 2000 Hz Red laser / blue laser</p>	<p>scanCONTROL 2900</p>	<p>scanCONTROL 2910</p>
 <p>LLT30x2 1024 points/profile Profile frequency up to 10000 Hz Red laser / blue laser</p>	<p>scanCONTROL 3002</p>	<p>scanCONTROL 3012</p>
 <p>LLT30x0 2048 points/profile Profile frequency up to 10000 Hz Red laser / blue laser</p>	<p>scanCONTROL 3000</p>	<p>scanCONTROL 3010</p>
	3D evaluation with 3DInspect or integration (SDK for C/ C++, LabView-VI, Cognex VisionPro and examples for C#, Linux and VB are available.)	Evaluation: scanCONTROL Configuration Tools

Measurement areas scanCONTROL

scanCONTROL 2500 and 2900

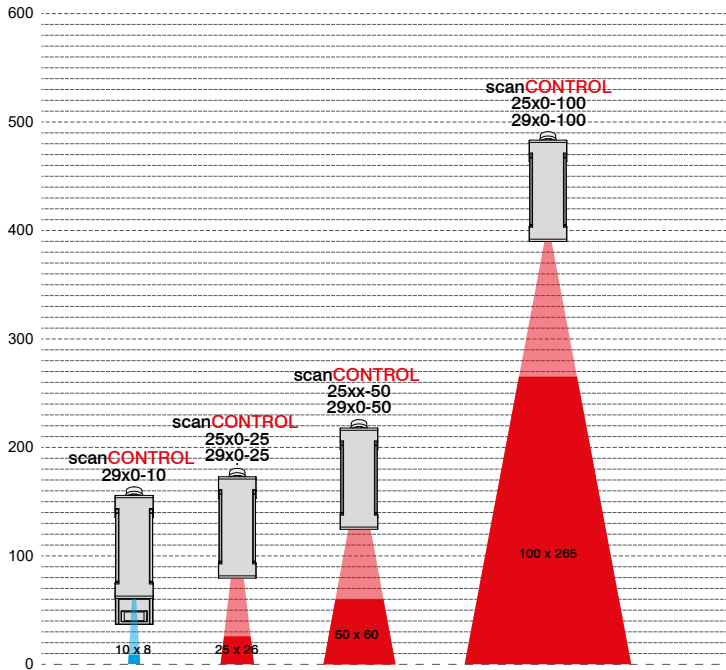

scanCONTROL laser profile scanners feature a wide range of different measurement areas from 10 x 8 mm up to 600 x 600 mm. Regardless of the size of the measurement area, these laser scanners impress with fast measurements and high precision at the same time.

The variety of measurement areas allows, on the one hand, both the acquisition of smallest details and structures, and, on the other hand, the measurement of large objects with a large offset distance. For this reason, scanCONTROL sensors are used for numerous measurement tasks in various industries.

scanCONTROL 3002 and 3000

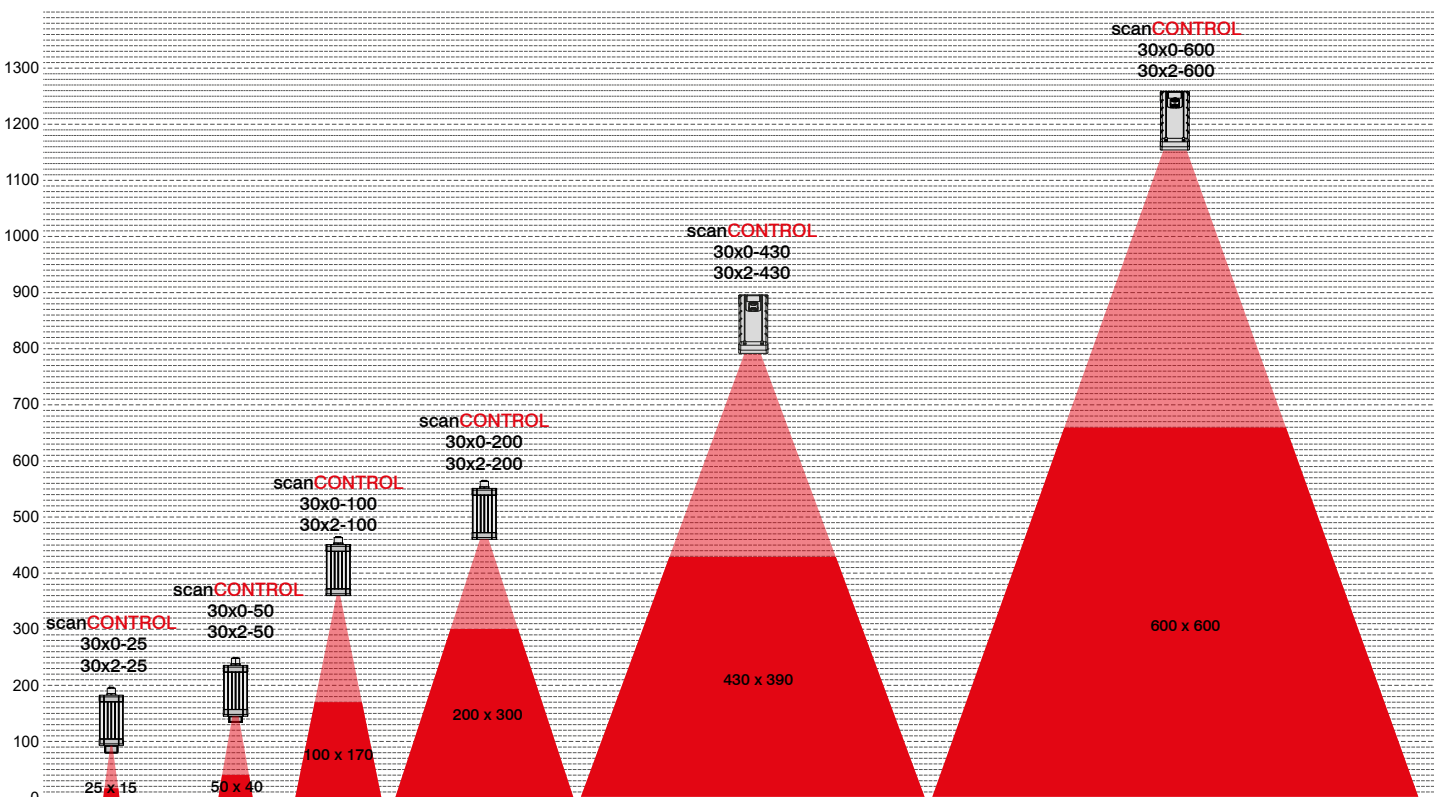

Application examples

scanCONTROL

scanCONTROL

Red laser scanners are ideally suited to numerous measurement tasks. A higher light intensity and better performance on weakly reflective or matt surfaces, especially with fast moving objects, make the red laser scanners ideal for common measurement tasks.

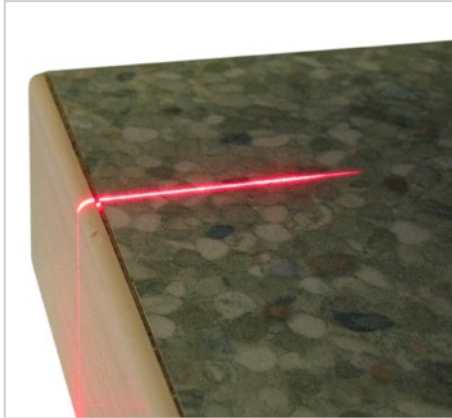

Defect recognition on worktops

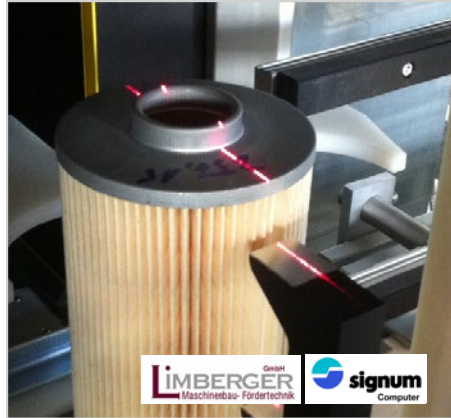

Filter height measurement for the automotive industry

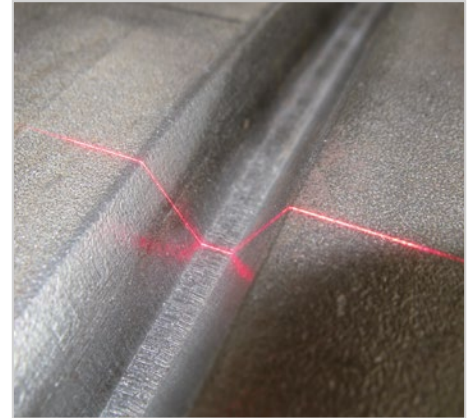

V-gap measurement on pipes



Gap measurement on car bodies



Profile measurement of the brake disc



Text recognition on the cast part



Tire control



Distance measurement at the center console

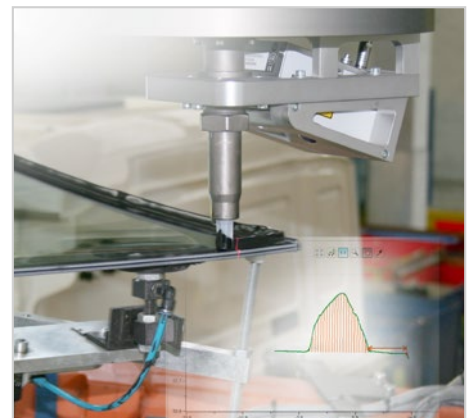

Inspection of the adhesive beading

scanCONTROL BL

For profile measurements on red-hot glowing metals as well as transparent and organic surfaces, laser scanners with blue laser line are recommended. While allowing higher stability, the blue laser light does not penetrate the measuring object due to the shorter wavelength of the blue-violet laser. Compared to red lasers, blue laser sensors ensure higher reliability with measurements on red-hot glowing, organic and (semi-)transparent objects.

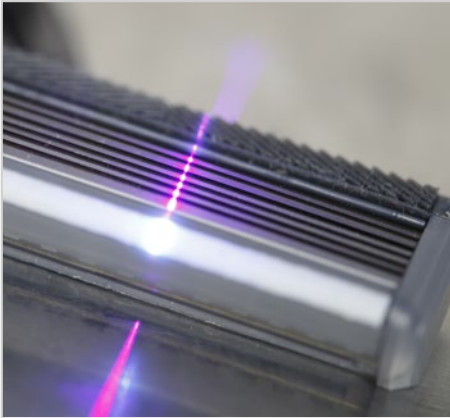

Razor blade angle

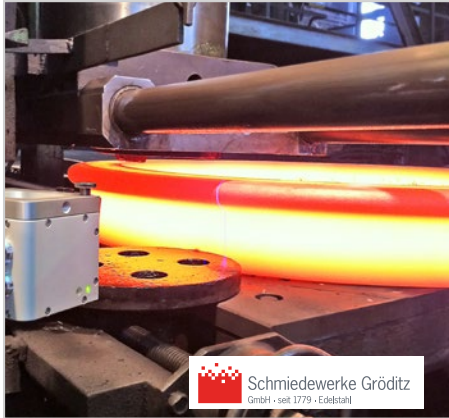

Production of steel-forged rings

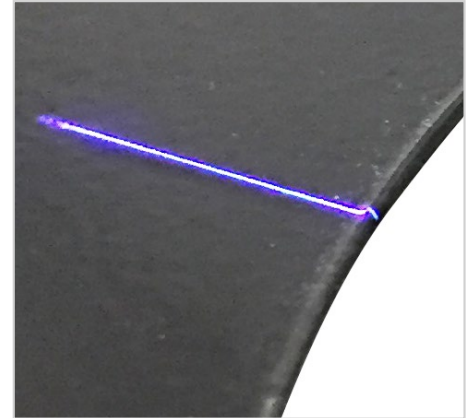

Burr measurement on punched sheets

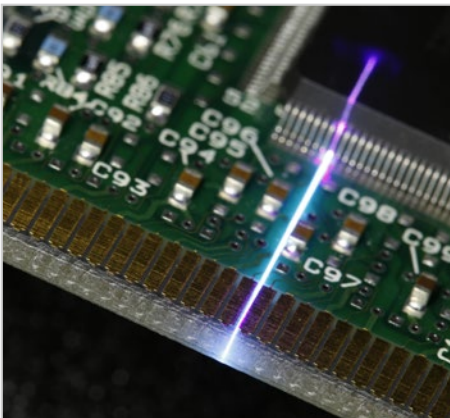

Position of electronic components

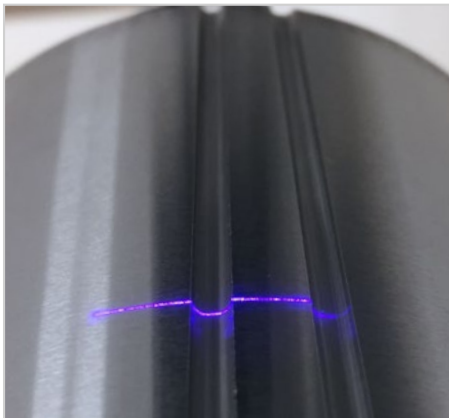

Notch position in silicon ingots

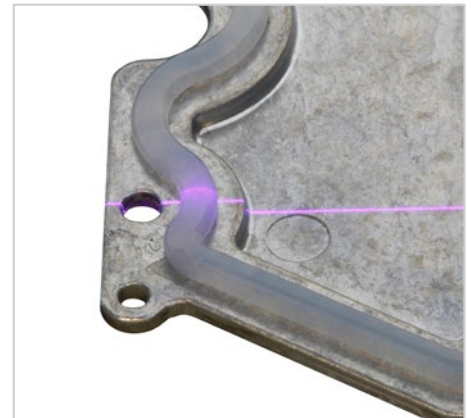

Inspection of silicone beads

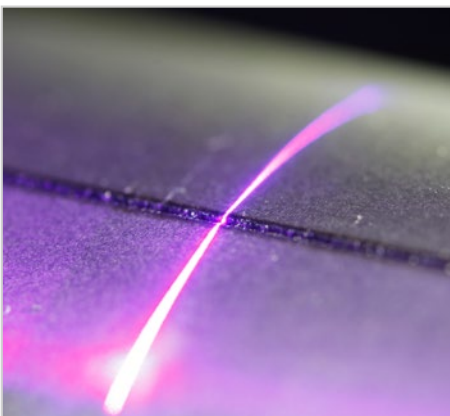

Completeness of laser welding seams



Thermal tests

Blue Laser patent protection with red-hot glowing and transparent surfaces

Measurements involving blue laser scanners on red-hot glowing objects exceeding 700 °C and (semi-)transparent objects are protected by patent law. Transparent objects include plastics, glass, adhesives, silicones, paints, coatings, Plexiglas and seals. Any questions about Blue Laser scanners? We will be pleased to advise you.

Laser scanner for industrial series applications

scanCONTROL 25x0

Ideal for industrial series applications in production line & automation

Resolution (x-axis) 640 points

High signal stability

Also available with patented Blue Laser Technology

Numerous references worldwide

Compatible with **COGNEX® VisionPro**



Ideal for series applications

scanCONTROL 25x0 laser scanners are designed for industrial measurement tasks. Thanks to their high signal stability, versatility and excellent price-performance ratio, the scanners are particularly suitable for measurement tasks involving large quantities. They measure and evaluate, e.g., angles, steps, gaps, distances and extreme values. Due to their compact design and low weight, these scanners are also suitable for applications with high accelerations, such as on robots.

Available as PROFILE and SMART versions

The scanCONTROL 25x0 series is available as PROFILE and SMART versions. The PROFILE scanners provide calibrated profile data that can be further processed on a PC with software evaluation provided by the customer. SMART scanners operate autonomously and provide selected measurement values. The sensor parameters and the desired measuring programs are set in the scanCONTROL Configuration Tools software and directly stored in the internal controller.

Ideal for production and machine monitoring

The scanCONTROL 25x0 laser scanners are available with three measuring ranges with red or blue laser. Optional accessories, cable types and interface modules allow a wide range of applications in the production line and in machine building.

Article designation

LLT	25	00	-25	/PT
Options - see below				
Measuring ranges				
25 mm				
50 mm				
100 mm				
Class				
00=PROFILE				
10=SMART				
Series				
LLT25x0				

Laser options*

	/SI	Hardware switch-off of the laser line
	/3B	Increased laser power (class 3B, ≤ 20 mW), e.g., for dark surfaces
	/BL	Blue laser line (405 nm) for (semi-) transparent, red-hot glowing and organic materials

Cable outlet options*

	/PT	Cable directly out of the sensor ("Pigtail") Length 0.3 m
--	-----	--

*Options can be combined

Accessories from page 42

Model		LLT 25xx-25	LLT 25xx-50	LLT 25xx-100	
Available laser type		Red Laser Blue Laser	Red Laser Blue Laser	Red Laser Blue Laser	
z-axis	Measuring ranges	Start of measuring range	53.5 mm	70 mm	190 mm
		Mid of measuring range	66 mm	95 mm	240 mm
		End of measuring range	78.5 mm	120 mm	290 mm
	Extended measuring range	Height of measuring range	25 mm	50 mm	100 mm
		Start of measuring range	53 mm	65 mm	125 mm
		End of measuring range	79 mm	125 mm	390 mm
Line linearity ^{1) 2)}		2 μ m	4 μ m	12 μ m	
		± 0.008 %	± 0.008 %	± 0.012 %	
x-axis	Measuring range	Start of measuring range	23.4 mm	42 mm	83.1 mm
		Mid of measuring range	25 mm	50 mm	100 mm
		End of measuring range	29.1 mm	58 mm	120.8 mm
	Extended measuring range	Start of measuring range	23.2 mm	40 mm	58.5 mm
		End of measuring range	29.3 mm	60 mm	143.5 mm
Resolution		640 points/profile			
Profile frequency		up to 2,000 Hz			
Interfaces	Ethernet GigE Vision	Output of measurement values Sensor control Profile data transmission			
	Digital inputs	Mode switching Encoder (counter) Trigger			
	RS422 (half-duplex) ³⁾	Output of measurement values Sensor control Trigger Synchronization			
Output of measurement values		Ethernet (UDP / Modbus TCP); RS422 (ASCII / Modbus RTU) analog ⁴⁾ ; switch signal ⁴⁾ PROFINET ⁵⁾ ; EtherCAT ⁵⁾ ; EtherNet/IP ⁵⁾			
Control and display elements		3x color LEDs for laser, data and error			
Light source		≤ 8 mW			
	Red Laser	Standard: laser class 2M, semiconductor laser 658 nm			
		≤ 20 mW			
		Option: laser class 3B, semiconductor laser 658 nm			
	Blue Laser	≤ 8 mW			
		Standard: laser class 2M, semiconductor laser 405 nm			
	Laser switch-off	via software, hardware switch-off with /SI option			
Aperture angle of laser line		20°	25°	25°	
Permissible ambient light (fluorescent light) ¹⁾		10,000 lx			
Protection class (DIN EN 60529)		IP65 (when connected)			
Vibration (DIN EN 60068-2-27)		2 g / 20 ... 500 Hz			
Shock (DIN EN 60068-2-6)		15 g / 6 ms			
Temperature range	Storage	-20 ... +70 °C			
	Operation	0 ... +45 °C			
Weight		380 g (without cable)			
Supply voltage		11 ... 30 VDC, nominal value 24 V, 500 mA, IEEE 802.3af class 2, Power over Ethernet (PoE)			

¹⁾ Based on the measuring range; measuring object: Micro-Epsilon standard object

²⁾ According to a one-time averaging over the measuring field (640 points)

³⁾ RS422 interface, programmable either as serial interface or as input for triggering/synchronization

⁴⁾ Only with 2D/3D Output Unit

⁵⁾ Only with 2D/3D Gateway

Compact laser scanner with high precision scanCONTROL 29x0

Ideal for precise 2D/3D measurements

Resolution (x-axis) 1,280 points

High accuracy for the detection of finest details

Profile frequency up to 2,000 Hz

Also available with patented Blue Laser Technology

Compatible with **COGNEX® VisionPro**



Compact design for precise measurements

scanCONTROL 29x0 laser scanners are designed for industrial measurement tasks where compact design and high accuracy are required. Thanks to their high resolution, versatility and excellent price-performance ratio, the scanners are particularly suitable for static and dynamic applications, e.g., on robots. They measure and evaluate, e.g., angles, steps, gaps, distances and extreme values.

Available as PROFILE and SMART versions

The scanCONTROL 29x0 series is available as PROFILE and SMART versions. The PROFILE scanners provide calibrated profile data that can be further processed on a PC with software evaluation provided by the customer. SMART scanners operate autonomously and provide selected measurement values. The sensor parameters and the desired measuring programs are set in the scanCONTROL Configuration Tools software and directly stored in the internal controller.

Small measuring range with high resolution

With a laser line of just 10 mm, the scanCONTROL 29x0-10/BL models recognize the finest of details and structures. The high profile resolution combined with the blue laser line allow for maximum precision in versatile applications, e.g., monitoring in electronics production.

Article designation

LLT	29	00	-25	/SI
Options - see below				
Measuring range				
10 mm (only Blue Laser)				
25 mm				
50 mm				
100 mm				
Class				
00=PROFILE				
10=SMART				
50=HIGHSPEED				
60=HIGHSPEED SMART				
Series				
LLT29x0				

Laser options*

	/SI	Hardware switch-off of the laser line
	/3B	Increased laser power (class 3B, ≤ 20 mW), e.g., for dark surfaces
	/BL	Blue laser line (405 nm) for (semi-) transparent, red-hot glowing and organic materials

Cable outlet options*

	/PT	Cable directly out of the sensor ("Pigtail") Length 0.3 m
	/VT	Cable directly out of the sensor ("Variable Tail") Length 0.1 ... 1.0 m (freely selectable)

*Options can be combined

Accessories from page 42

Model		LLT29x0-10/BL	LLT 29xx-25	LLT 29xx-50	LLT 29xx-100	
Available laser type		Blue Laser	Red Laser Blue Laser	Red Laser Blue Laser	Red Laser Blue Laser	
z-axis	Measuring range	Start of measuring range	52.5 mm	53.5 mm	70 mm	190 mm
		Mid of measuring range	56.5 mm	66 mm	95 mm	240 mm
		End of measuring range	60.5 mm	78.5 mm	120 mm	290 mm
		Height of measuring range	8 mm	25 mm	50 mm	100 mm
	Extended measuring range	Start of measuring range	-	53 mm	65 mm	125 mm
		End of measuring range	-	79 mm	125 mm	390 mm
Line linearity ¹⁾²⁾		1 μm	2 μm	4 μm	12 μm	
		±0.0125 %	±0.008 %	±0.008 %	±0.012 %	
x-axis	Measuring range	Start of measuring range	9.4 mm	23.4 mm	42 mm	83.1 mm
		Mid of measuring range	10 mm	25 mm	50 mm	100 mm
		End of measuring range	10.7 mm	29.1 mm	58 mm	120.8 mm
	Extended measuring range	Start of measuring range	-	23.2 mm	40 mm	58.5 mm
		End of measuring range	-	29.3 mm	60 mm	143.5 mm
	Resolution		1,280 points/profile			
Profile frequency	Standard	up to 300 Hz				
	High speed	up to 2000 Hz				
Interfaces	Ethernet GigE Vision	Output of measurement values Sensor control Profile data transmission				
	Digital inputs	Mode switching Encoder (counter) Trigger				
	RS422 (half-duplex) ³⁾	Output of measurement values Sensor control Trigger Synchronization				
Output of measurement values	Ethernet (UDP / Modbus TCP); RS422 (ASCII / Modbus RTU) analog ⁴⁾ ; switch signal ⁴⁾ PROFINET ⁵⁾ ; EtherCAT ⁵⁾ ; EtherNet/IP ⁵⁾					
Control and display elements	3x color LEDs for laser, data and error					
Light source		-	≤ 8 mW			
	Red Laser	-	Standard: laser class 2M, semiconductor laser 658 nm			
		-	≤ 20 mW			
		-	Option: laser class 3B, semiconductor laser 658 nm			
	Blue Laser		≤ 8 mW			
			Standard: laser class 2M, semiconductor laser 405 nm			
	Laser switch-off	via software, hardware switch-off with /SI option				
Aperture angle of laser line		10°	20°	25°	25°	
Permissible ambient light (fluorescent light) ¹⁾		10,000 lx				
Protection class (DIN EN 60529)		IP65 (when connected)				
Vibration (DIN EN 60068-2-27)		2 g / 20 ... 500 Hz				
Shock (DIN EN 60068-2-6)		15 g / 6 ms				
Temperature range	Storage	-20 ... +70 °C				
	Operation	0 ... +45 °C				
Weight		440 g (without cable)	380 g (without cable)			
Supply voltage		11 ... 30 VDC, nominal value 24 V, 500 mA, IEEE 802.3af class 2, Power over Ethernet (PoE)				

¹⁾ Based on the measuring range; measuring object: Micro-Epsilon standard object

²⁾ According to a one-time averaging over the measuring field (640 points)

³⁾ RS422 interface, programmable either as serial interface or as input for triggering/synchronization

⁴⁾ Only with 2D/3D Output Unit

⁵⁾ Only with 2D/3D Gateway

Dimensions and measuring ranges

scanCONTROL

LLT29x0-10/BL

Blue Laser

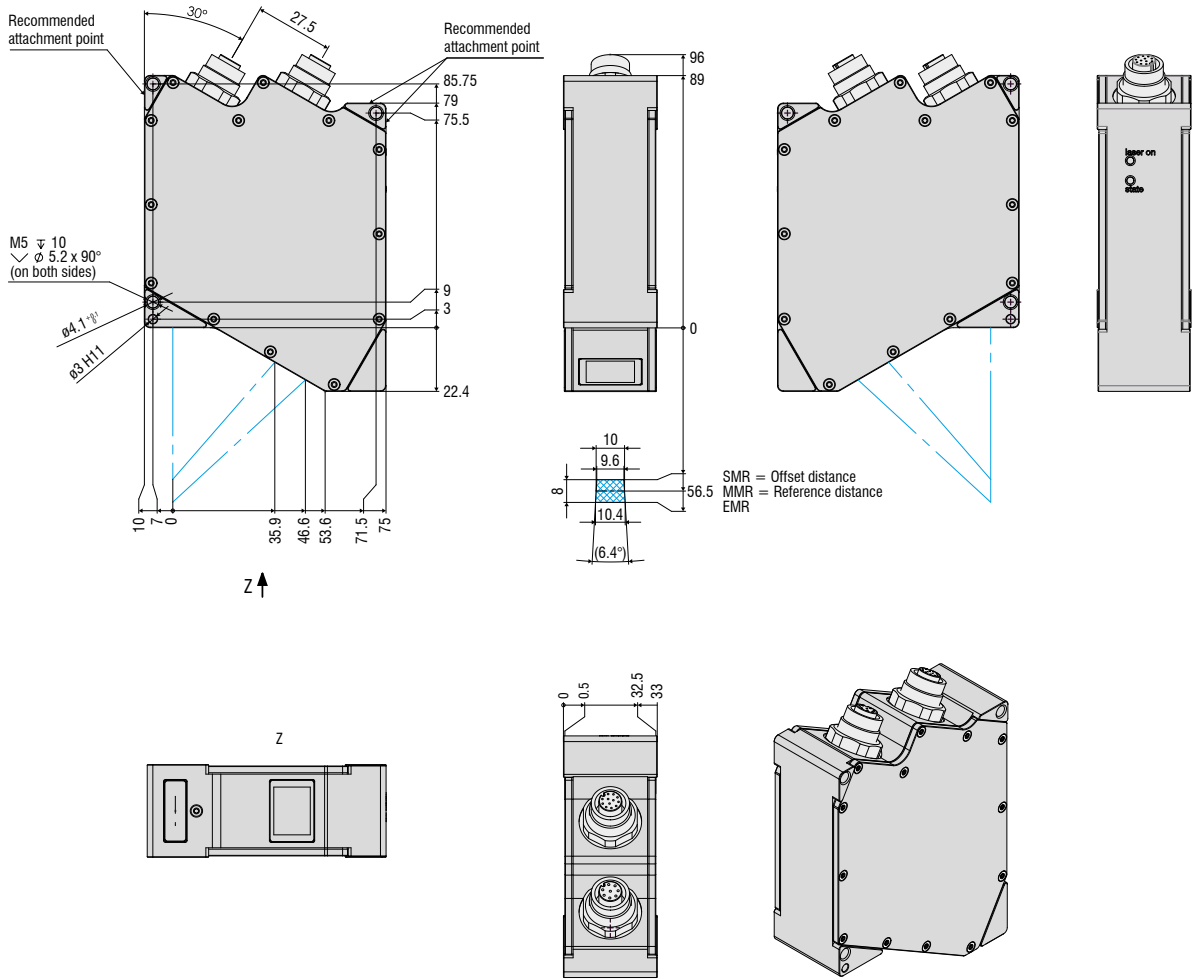

LLT25x0-25 / LLT29x0-25

Red Laser

Blue Laser

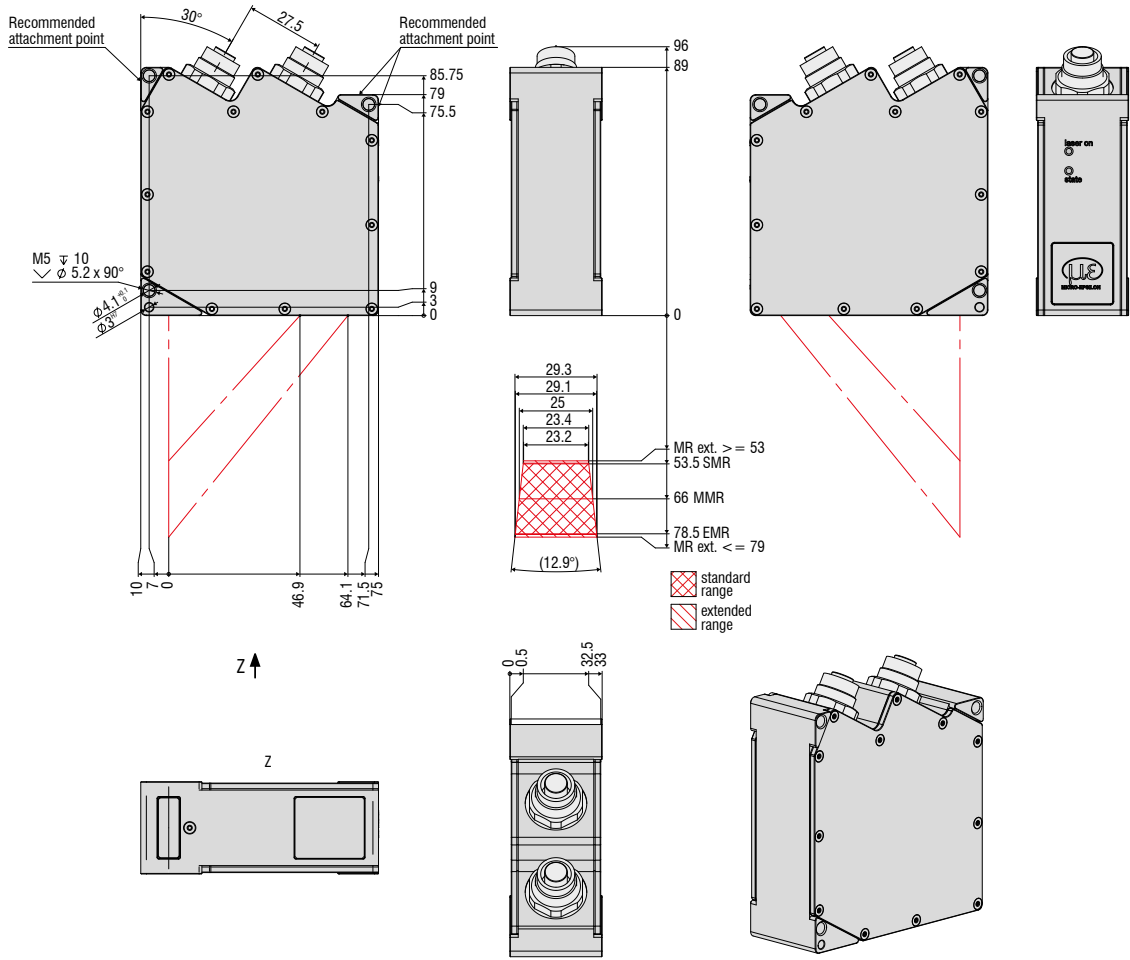

Dimensions and measuring ranges

scanCONTROL

LLT25x0-50 / LLT29x0-50

Red Laser

Blue Laser

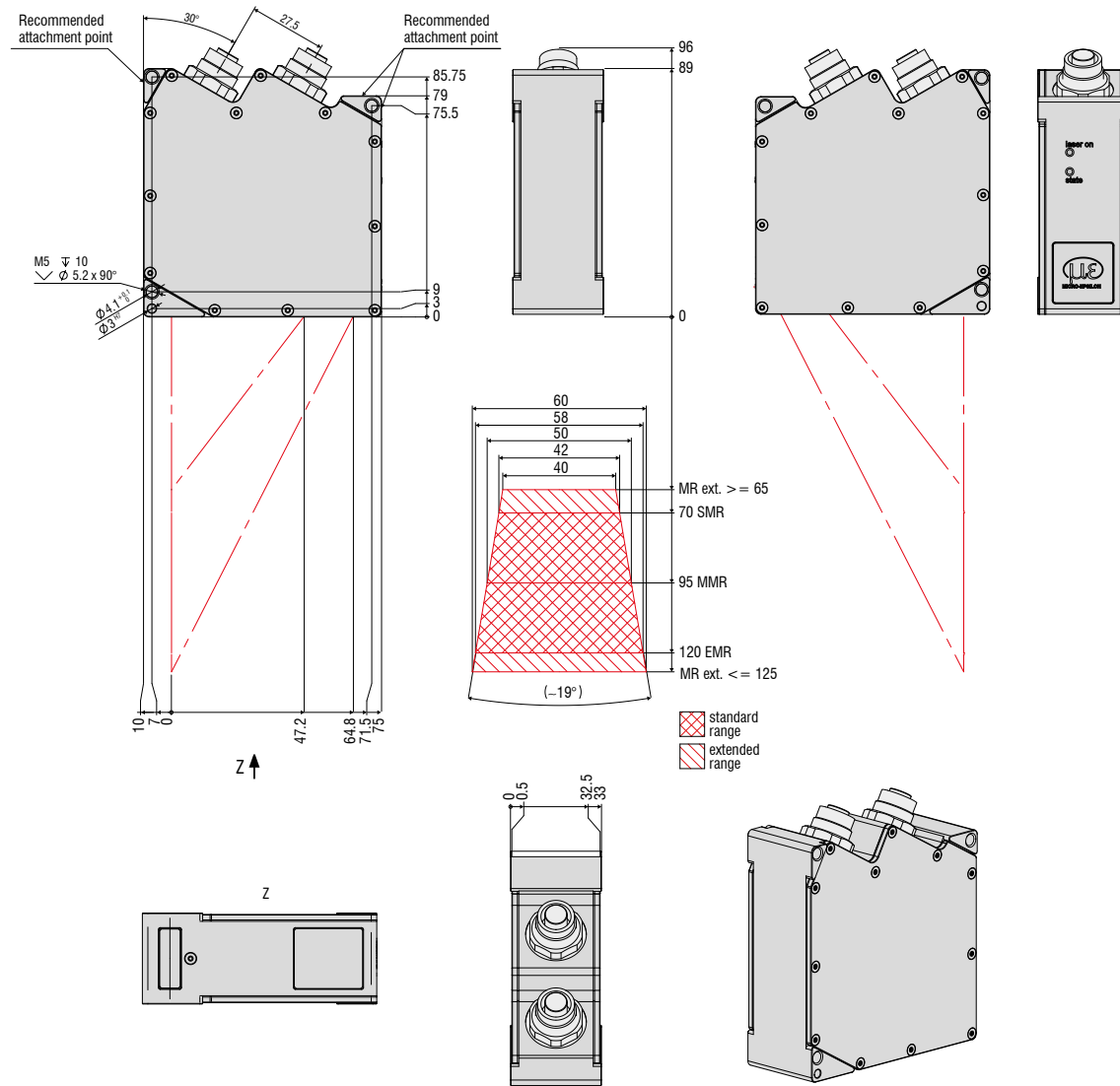

LLT25x0 / LLT29x0-100

Red Laser

Blue Laser

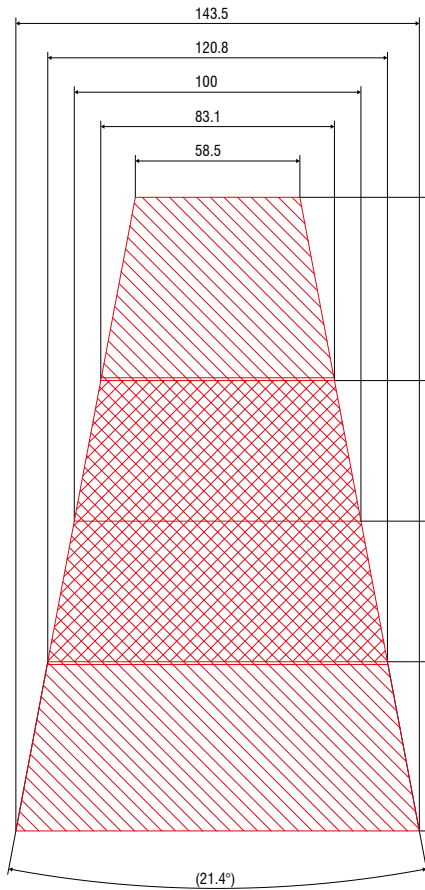
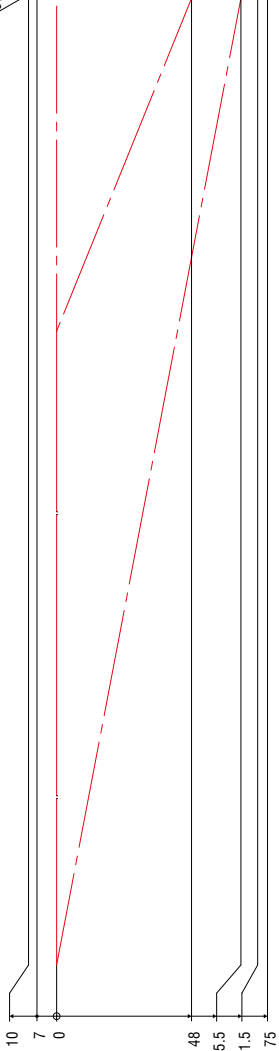
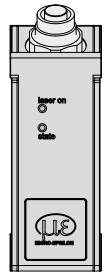
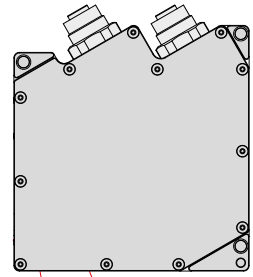
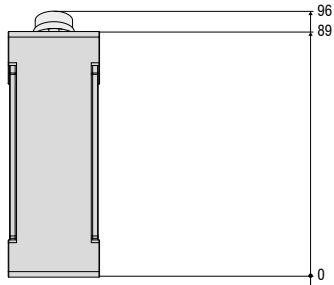
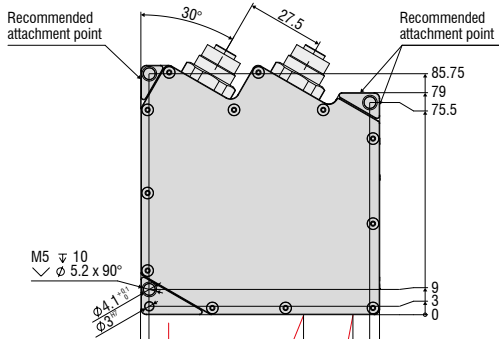

MR ext. \geq 125

190 SMR

240 MMR

290 EMR

MR ext. \leq 390

standard range

extended range

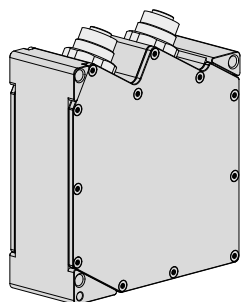
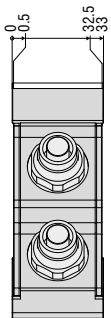
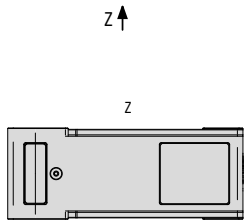

Powerful 2D/3D laser scanners

scanCONTROL 30x2

Precise profile measurements for industrial measurement tasks

Resolution (x-axis) 1,024 points

Profile frequency up to 10,000 Hz

For small and large measuring ranges

Also available with patented Blue Laser Technology

Compatible with **COGNEX® VisionPro**



Precise 2D/3D profile measurements

The new LLT30x2 laser profile scanners provide calibrated profile data with up to 7.9 million points per second. They allow profile frequencies up to 10 kHz and resolutions up to 1,024 points. Thanks to their high accuracy and versatility, the scanners are particularly suitable for static and dynamic applications as well as robotic applications. They measure and evaluate, e. g., angles, steps, gaps, distances, and circles.

Available as PROFILE and SMART versions

The scanCONTROL 30x2 series is available as PROFILE and SMART versions. The PROFILE scanners provide calibrated profile data that can be further processed on a PC with software evaluation provided by the customer. The 3DInspect software allows for the scanCONTROL sensors to be used also for 3D evaluations.

SMART scanners operate autonomously and provide selected measurement values. The scanCONTROL 30x2 series supports all SMART functions and programs that are set in the scanCONTROL Configuration Tools software and directly stored in the internal controller.



Article designation

LLT	30	x2	-25	/SI
Options - see below				
Measuring range				
25 mm				
50 mm				
100 mm				
200 mm				
430 mm				
600 mm				
Class				
02 = PROFILE				
12 = SMART				
Series				
LLT30xx				

Laser options*

	/SI	Hardware switch-off of the laser line
	/3R	Increased laser power (class 3R) e.g., for dark surfaces
	/BL	Blue laser line (405 nm) for (semi-) transparent, red-hot glowing and organic materials (Measuring ranges 25 - 100 mm)

Cable outlet options*

	/RT	Cable outlet on the rear side ("Rear Tail") for space-saving installation, cable length 0.3 m. Sockets at cable end (Measuring ranges 25 - 200 mm)
	/PT	Cable directly out of the sensor ("Pigtail") Available lengths: 0.3 / 0.6 / 1.00 m

*Options can be combined

Accessories from page 42



The easy way of machine integration

The design of the LLT30x2 series is compact and lightweight. The controller is integrated in the sensor itself, which simplifies mechanical integration. The measurement data can be output directly.

NEW

Large measurement area up to 600 x 600 mm

The scanCONTROL 30x2 laser scanners are now also available with a large measuring field up to 600 x 600 mm. This allows large measuring objects to be detected with high accuracy.

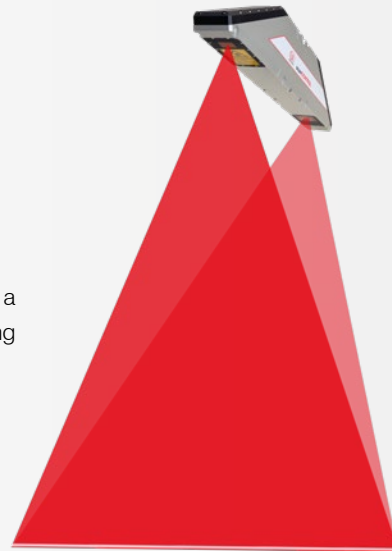

Application examples

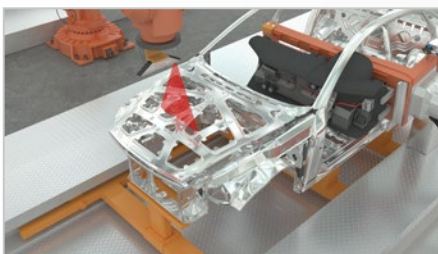

Assembly monitoring of car body shell construction



Detection of the road surface profile



Geometry inspection in metals processing

Powerful 2D/3D laser scanners

scanCONTROL 30x2

Model		LLT 30x2-25	LLT 30x2-50	LLT 30x2-100	LLT 30x2-200	
Available laser type		Red Laser Blue Laser	Red Laser Blue Laser	Red Laser Blue Laser	Red Laser	
Z-axis	Measuring range	Start of measuring range	77.5 mm	105 mm	200 mm	200 mm
		Mid of measuring range	85 mm	125 mm	270 mm	310 mm
		End of measuring range	92.5 mm	145 mm	340 mm	420 mm
	Extended measuring range	Height of measuring range	15 mm	40 mm	140 mm	220 mm
		Start of measuring range	-	-	190 mm	160 mm
	End of measuring range	-	-	360 mm	460 mm	
	Line linearity ^{1) 2)}	2 μ m	4 μ m	10 μ m	30 μ m	
	± 0.013 %	± 0.01 %	± 0.007 %	± 0.014 %		
X-axis	Measuring range	Start of measuring range	23.0 mm	43.3 mm	75.6 mm	130 mm
		Mid of measuring range	25.0 mm	50.0 mm	100 mm	200 mm
		End of measuring range	26.8 mm	56.5 mm	124.4 mm	270 mm
	Extended measuring range	Start of measuring range	-	-	72.1 mm	100 mm
		End of measuring range	-	-	131.1 mm	290 mm
	Resolution	1,024 points/profile				
	Profile frequency	up to 10,000 Hz				
Interfaces	Ethernet GigE Vision	Output of measurement values Sensor control Profile data transmission				
	Digital inputs	Mode switching Encoder (counter) Trigger				
	RS422 (half-duplex) ³⁾	Output of measurement values Sensor control Trigger Synchronization				
Output of measurement values	Ethernet (UDP / Modbus TCP); RS422 (ASCII / Modbus RTU) analog ⁴⁾ ; switch signal ⁴⁾ PROFINET ⁵⁾ ; EtherCAT ⁵⁾ ; EtherNet/IP ⁵⁾					
Control and display elements	3x color LEDs for laser, data and error					
Light source	Red Laser	≤ 10 mW		≤ 12 mW		
		Standard: laser class 2M, semiconductor laser 658 nm				
	≤ 30 mW		≤ 50 mW			
	Option: laser class 3R, semiconductor laser 658 nm					
	Blue Laser	≤ 10 mW		-		
Laser switch-off	Standard: laser class 2M, semiconductor laser 405 nm					
Aperture angle of laser line	23°	28°	30°	45°		
Permissible ambient light (fluorescent light) ¹⁾	10,000 lx					
Protection class (DIN EN 60529)	IP67 (when connected)					
Vibration (DIN EN 60068-2-27)	2 g / 20 ... 500 Hz					
Shock (DIN EN 60068-2-6)	15 g / 6 ms					
Temperature range	Storage	-20 ... +70 °C				
	Operation	0 ... +45 °C				
Weight	415 g (without cable)					
Supply voltage	11 ... 30 VDC, nominal value 24 V, 500 mA, IEEE 802.3af class 2, Power over Ethernet (PoE)					

¹⁾ Based on the measuring range; measuring object: Micro-Epsilon standard object

²⁾ According to a one-time averaging over the measuring field (1,024 points)

³⁾ RS422 interface, programmable either as serial interface or as input for triggering/synchronization

⁴⁾ Only with 2D/3D Output Unit

⁵⁾ Only with 2D/3D Gateway

Model		LLT 30x2-430	LLT 30x2-600	
Available laser type		Red Laser	Red Laser	
z-axis	Measuring range	Start of measuring range	330 mm	530 mm
		Mid of measuring range	515 mm	770 mm
		End of measuring range	700 mm	1010 mm
	Extended measuring range	Height of measuring range	370 mm	480 mm
		Start of measuring range	330 mm	450 mm
	End of measuring range	720 mm	1050 mm	
Line linearity ^{1) 2)}		15 μm	22 μm	
		±0.0041 %	±0.0045 %	
x-axis	Measuring range	Start of measuring range	324 mm	456 mm
		Mid of measuring range	430 mm	600 mm
		End of measuring range	544 mm	762 mm
	Extended measuring range	Start of measuring range	324 mm	408 mm
End of measuring range		560 mm	788 mm	
Resolution		1,024 points/profile		
Profile frequency		up to 10,000 Hz		
Interfaces	Ethernet GigE Vision	Output of measurement values Sensor control Profile data transmission		
	Digital inputs	Mode switching Encoder (counter) Trigger		
	RS422 (half-duplex) ³⁾	Output of measurement values Sensor control Trigger Synchronization		
Output of measurement values		Ethernet (UDP / Modbus TCP); RS422 (ASCII / Modbus RTU) analog ⁴⁾ ; switch signal ⁴⁾ PROFINET ⁵⁾ ; EtherCAT ⁵⁾ ; EtherNet/IP ⁵⁾		
Control and display elements		3x color LEDs for laser, data and error		
Light source	Red Laser	≤ 26 mW		
		Standard: laser class 2M, semiconductor laser 660 nm		
		≤ 100 mW		
	Option: laser class 3R, semiconductor laser 660 nm			
Laser switch-off		via software, hardware switch-off with /SI option		
Aperture angle of laser line		60 °		
Permissible ambient light (fluorescent light) ¹⁾		5,000 lx		
Protection class (DIN EN 60529)		IP67 (when connected)		
Vibration (DIN EN 60068-2-27)		2 g / 20 ... 500 Hz		
Shock (DIN EN 60068-2-6)		15 g / 6 ms		
Temperature range	Storage	-20 ... +70 °C		
	Operation	0 ... +45 °C		
Weight		2620 g (without cable)		
Supply voltage		11 ... 30 VDC, nominal value 24 V, 500 mA, IEEE 802.3af class 2, Power over Ethernet (PoE)		
Connections		Sockets, cable outlets on top (/PT)		

¹⁾ Based on the measuring range; measuring object: Micro-Epsilon standard object

²⁾ According to a one-time averaging over the measuring field (1,024 points)

³⁾ RS422 interface, programmable either as serial interface or as input for triggering/synchronization

⁴⁾ Only with 2D/3D Output Unit

⁵⁾ Only with 2D/3D Gateway

Powerful 2D/3D laser scanners with highest precision

scanCONTROL 30x0

High resolution in x- and z-axis for accurate profile measurement

Profile frequency up to 10 kHz for monitoring of dynamic processes

Innovative exposure control

For small and large measuring ranges

Also available with patented Blue Laser Technology

Compatible with **COGNEX® VisionPro**



Fast and precise 2D/3D profile measurements

The new LLT30x0 laser profile scanners provide calibrated profile data with up to 9.6 million points per second. Thanks to their high accuracy, high profile frequency and versatility, these powerful scanners are suitable for demanding measurement tasks. They measure and evaluate, e.g., angles, steps, gaps, distances and circles with high precision. These sensors also offer predefined operating modes that enable optimal results for various applications.

Article designation

LLT	30	x0	-25	/SI	
Options - see below					
Measuring range 25 mm 50 mm 100 mm 200 mm 430 mm 600 mm					
Class 00 = PROFILE 10 = SMART					
Series LLT30xx					

Available as PROFILE and SMART versions

The scanCONTROL 30x0 series is available as PROFILE and SMART versions. The PROFILE scanners provide calibrated profile data that can be further processed on a PC with software evaluation provided by the customer. The 3DInspect software allows for the scanCONTROL sensors to be used also for 3D evaluations.

SMART scanners operate autonomously and provide selected measurement values. The scanCONTROL 30x0 series supports all SMART functions and programs that are set in the scanCONTROL Configuration Tools software and directly stored in the internal controller.

Laser options*

	/SI	Hardware switch-off of the laser line
	/3R	Increased laser power (class 3R) e.g., for dark surfaces
	/BL	Blue laser line (405 nm) for (semi-) transparent, red-hot glowing and organic materials (Measuring ranges 25 - 100 mm)

Cable outlet options*

	/RT	Cable outlet on the rear side ("Rear Tail") for space-saving installation, cable length 0.3 m. Sockets at cable end (Measuring ranges 25 - 200 mm)
	/PT	Cable directly out of the sensor ("Pigtail") Available lengths: 0.3 / 0.6 / 1.00 m

*Options can be combined

Accessories from page 42

Innovative exposure control to master difficult surfaces

On inhomogeneous or dark surfaces, the HDR (High Dynamic Range) data acquisition mode and the improved auto exposure optimizes the measurement results.

In HDR mode, the rows of the sensor matrix are exposed differently but at the same time which avoids time offsets between the recordings. This is how moving objects can be detected reliably. The areas for auto exposure can be selected individually.

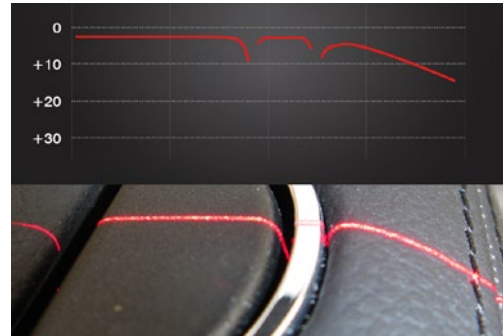

High resolution

High dynamic range

High speed

Fast measurement results with operation modes

Choose from three predefined operating modes for your specific measurement task: "High-Resolution" for maximum precision, "High Dynamic Range" for optimal profile detection on difficult surfaces and "High Speed" for ultra-fast measurements.

NEW

Large measurement area up to 600 x 600 mm

The scanCONTROL 30x2 laser scanners are now also available with a large measuring field up to 600 x 600 mm. This allows large measuring objects to be detected with high accuracy.



Application examples



Planarity of coated battery film

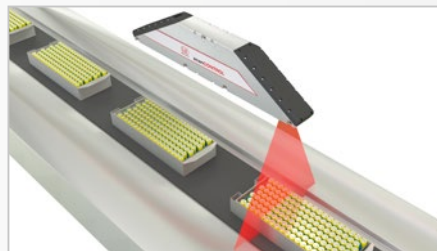

Assembly monitoring of battery packs



Inline 3D inspection of tire geometry

High performance laser scanner

scanCONTROL 30x0

Model		LLT 30x0-25	LLT 30x0-50	LLT 30x0-100	LLT 30x0-200	
Available laser type		Red Laser Blue Laser	Red Laser Blue Laser	Red Laser Blue Laser	Red Laser	
Z-axis	Measuring range	Start of measuring range	77.5 mm	105 mm	200 mm	200 mm
		Mid of measuring range	85 mm	125 mm	270 mm	310 mm
		End of measuring range	92.5 mm	145 mm	340 mm	420 mm
	Extended measuring range	Height of measuring range	15 mm	40 mm	140 mm	220 mm
		Start of measuring range	-	-	190 mm	160 mm
		End of measuring range	-	-	360 mm	460 mm
Line linearity ^{1) 2)}	1.5 μ m	3 μ m	9 μ m	26 μ m		
		± 0.01 %	± 0.0075 %	± 0.006 %	± 0.012 %	
X-axis	Measuring range	Start of measuring range	23.0 mm	43.3 mm	75.6 mm	130 mm
		Mid of measuring range	25.0 mm	50.0 mm	100 mm	200 mm
		End of measuring range	26.8 mm	56.5 mm	124.4 mm	270 mm
	Extended measuring range	Start of measuring range	-	-	72.1 mm	100 mm
		End of measuring range	-	-	131.1 mm	290 mm
Resolution		2,048 points/profile				
Profile frequency		up to 10,000 Hz				
Interfaces	Ethernet GigE Vision	Output of measurement values Sensor control Profile data transmission				
	Digital inputs	Mode switching Encoder (counter) Trigger				
	RS422 (half-duplex) ³⁾	Output of measurement values Sensor control Trigger Synchronization				
Output of measurement values	Ethernet (UDP / Modbus TCP); RS422 (ASCII / Modbus RTU) analog ⁴⁾ ; switch signal ⁴⁾ PROFINET ⁵⁾ ; EtherCAT ⁵⁾ ; EtherNet/IP ⁵⁾					
Control and display elements	3x color LEDs for laser, data and error					
Light source		≤ 10 mW			≤ 12 mW	
	Red Laser	Standard: laser class 2M, semiconductor laser 658 nm				
		≤ 30 mW		≤ 50 mW		
		Option: laser class 3R, semiconductor laser 658 nm				
	Blue Laser	≤ 10 mW			-	
		Standard: laser class 2M, semiconductor laser 405 nm				
Laser switch-off	via software, hardware switch-off with /SI option					
Aperture angle of laser line	23°	28°	30°	45°		
Permissible ambient light (fluorescent light) ¹⁾	10,000 lx					
Protection class (DIN EN 60529)	IP67 (when connected)					
Vibration (DIN EN 60068-2-27)	2 g / 20 ... 500 Hz					
Shock (DIN EN 60068-2-6)	15 g / 6 ms					
Temperature range	Storage	-20 ... +70 °C				
	Operation	0 ... +45 °C				
Weight	415 g (without cable)					
Supply voltage	11 ... 30 VDC, nominal value 24 V, 500 mA, IEEE 802.3af class 2, Power over Ethernet (PoE)					

¹⁾ Based on the measuring range; measuring object: Micro-Epsilon standard object

²⁾ According to a one-time averaging over the measuring field (2,048 points)

³⁾ RS422 interface, programmable either as serial interface or as input for triggering/synchronization

⁴⁾ Only with 2D/3D Output Unit

⁵⁾ Only with 2D/3D Gateway

Model		LLT 30x0-430	LLT 30x0-600	
Available laser type		Red Laser	Red Laser	
z-axis	Measuring range	Start of measuring range	330 mm	530 mm
		Mid of measuring range	515 mm	770 mm
		End of measuring range	700 mm	1010 mm
		Height of measuring range	370 mm	480 mm
	Extended measuring range	Start of measuring range	330 mm	450 mm
		End of measuring range	720 mm	1050 mm
	Line linearity ^{1) 2)}	12 μ m	15 μ m	
		± 0.0032 %	± 0.0031 %	
x-axis	Measuring range	Start of measuring range	324 mm	456 mm
		Mid of measuring range	430 mm	600 mm
		End of measuring range	544 mm	762 mm
	Extended measuring range	Start of measuring range	324 mm	408 mm
		End of measuring range	560 mm	788 mm
Resolution		2,048 points/profile		
Profile frequency		up to 10,000 Hz		
Interfaces	Ethernet GigE Vision	Output of measurement values Sensor control Profile data transmission		
	Digital inputs	Mode switching Encoder (counter) Trigger		
	RS422 (half-duplex) ³⁾	Output of measurement values Sensor control Trigger Synchronization		
Output of measurement values		Ethernet (UDP / Modbus TCP); RS422 (ASCII / Modbus RTU) analog ⁴⁾ ; switch signal ⁴⁾ PROFINET ⁵⁾ ; EtherCAT ⁵⁾ ; EtherNet/IP ⁵⁾		
Control and display elements		3x color LEDs for laser, data and error		
Light source	Red Laser		≤ 26 mW	
			Standard: laser class 2M, semiconductor laser 660 nm	
			≤ 100 mW	
	Laser switch-off		Option: laser class 3R, semiconductor laser 660 nm via software, hardware switch-off with /SI option	
Aperture angle of laser line		60 °		
Permissible ambient light (fluorescent light) ¹⁾		5,000 lx		
Protection class (DIN EN 60529)		IP67 (when connected)		
Vibration (DIN EN 60068-2-27)		2 g / 20 ... 500 Hz		
Shock (DIN EN 60068-2-6)		15 g / 6 ms		
Temperature range	Storage	-20 ... +70 °C		
	Operation	0 ... +45 °C		
Weight		2630 g (without cable)		
Supply voltage		11 ... 30 VDC, nominal value 24 V, 500 mA, IEEE 802.3af class 2, Power over Ethernet (PoE)		
Connections		Sockets, cable outlets on top (/PT)		

¹⁾ Based on the measuring range; measuring object: Micro-Epsilon standard object

²⁾ According to a one-time averaging over the measuring field (2,048 points)

³⁾ RS422 interface, programmable either as serial interface or as input for triggering/synchronization

⁴⁾ Only with 2D/3D Output Unit

⁵⁾ Only with 2D/3D Gateway

Options

scanCONTROL 30xx

NEW

Option /RT = "Rear Tail"

Cable outlet on the rear side ("Rear Tail") for space-saving installation

- Available for the measuring ranges from 25 to 200 mm
- 30 cm pigtail
- Reduces the installation height by 47%

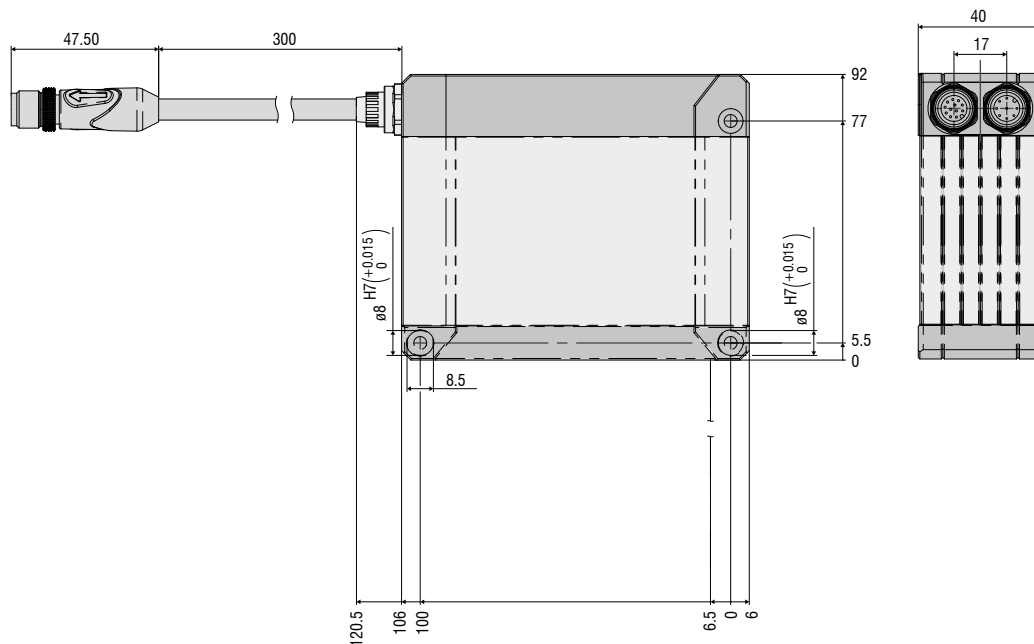
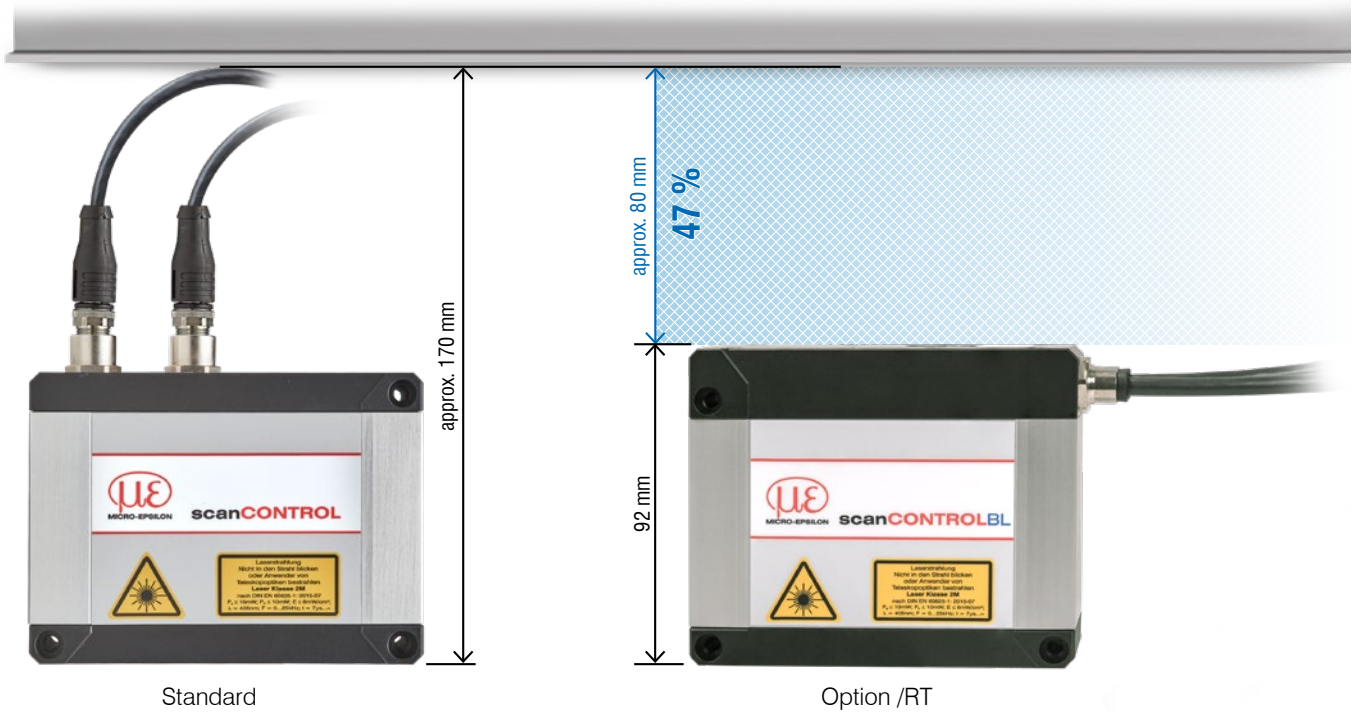

Dimensions and measuring ranges

scanCONTROL 30xx

LLT30x2-25 / LLT30x0-25

Red Laser

Blue Laser

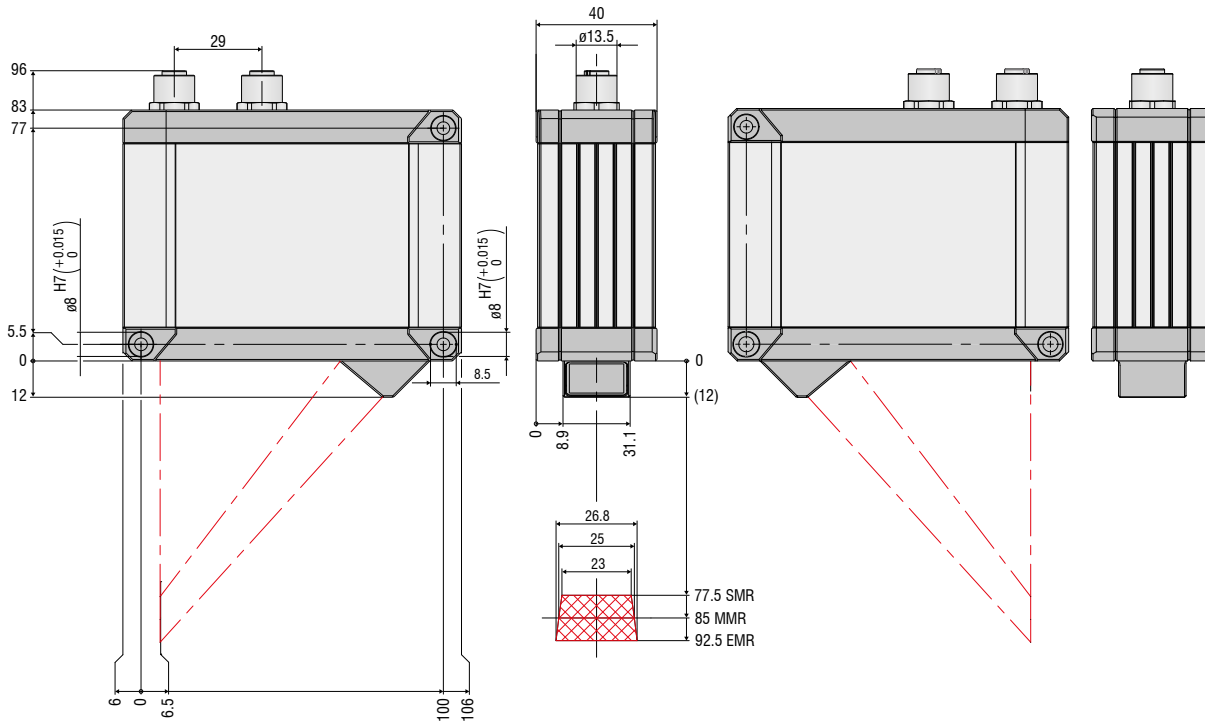

LLT30x2-50 / LLT30x0-50

Red Laser

Blue Laser

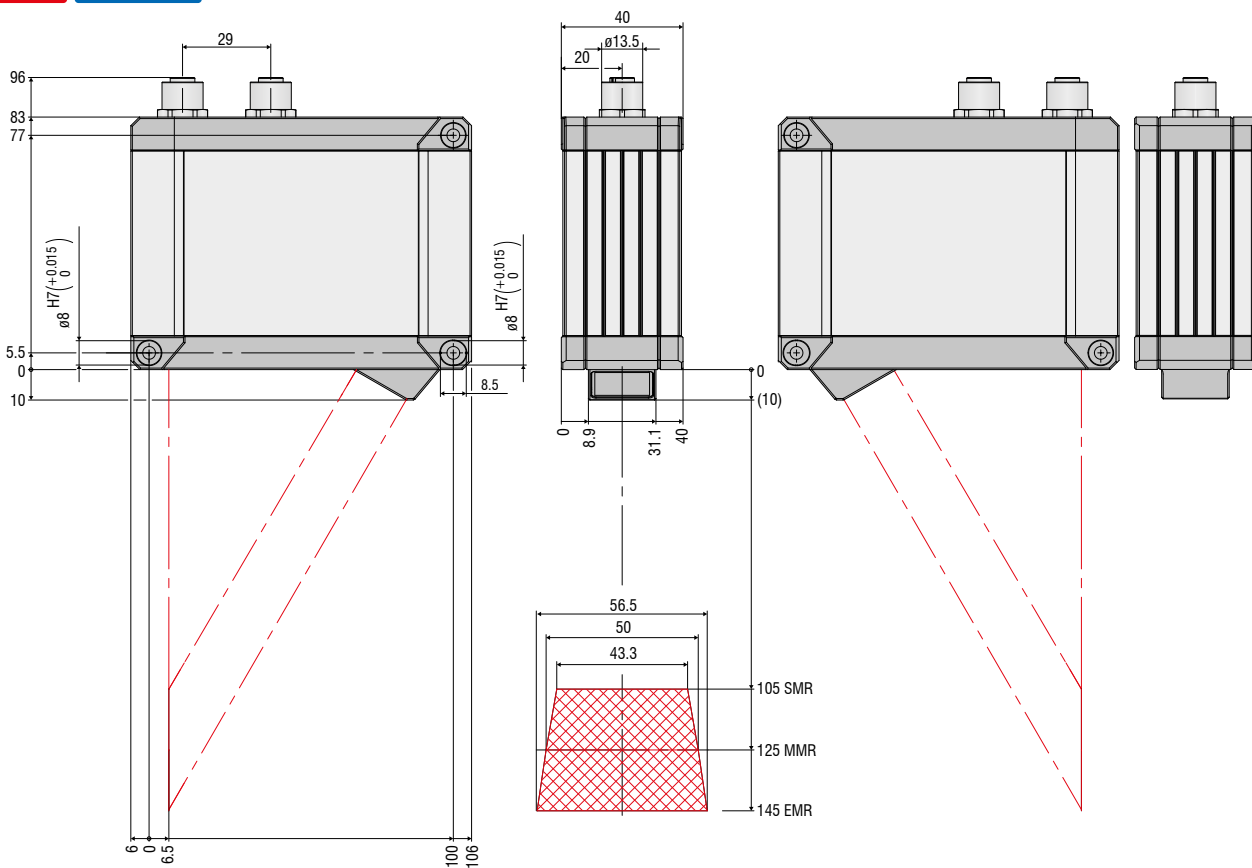

Dimensions and measuring ranges

scanCONTROL 30xx

LLT30x2-100 / LLT30x0-100

Red Laser

Blue Laser

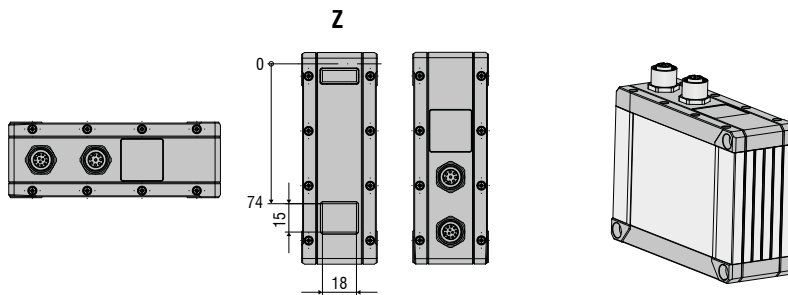
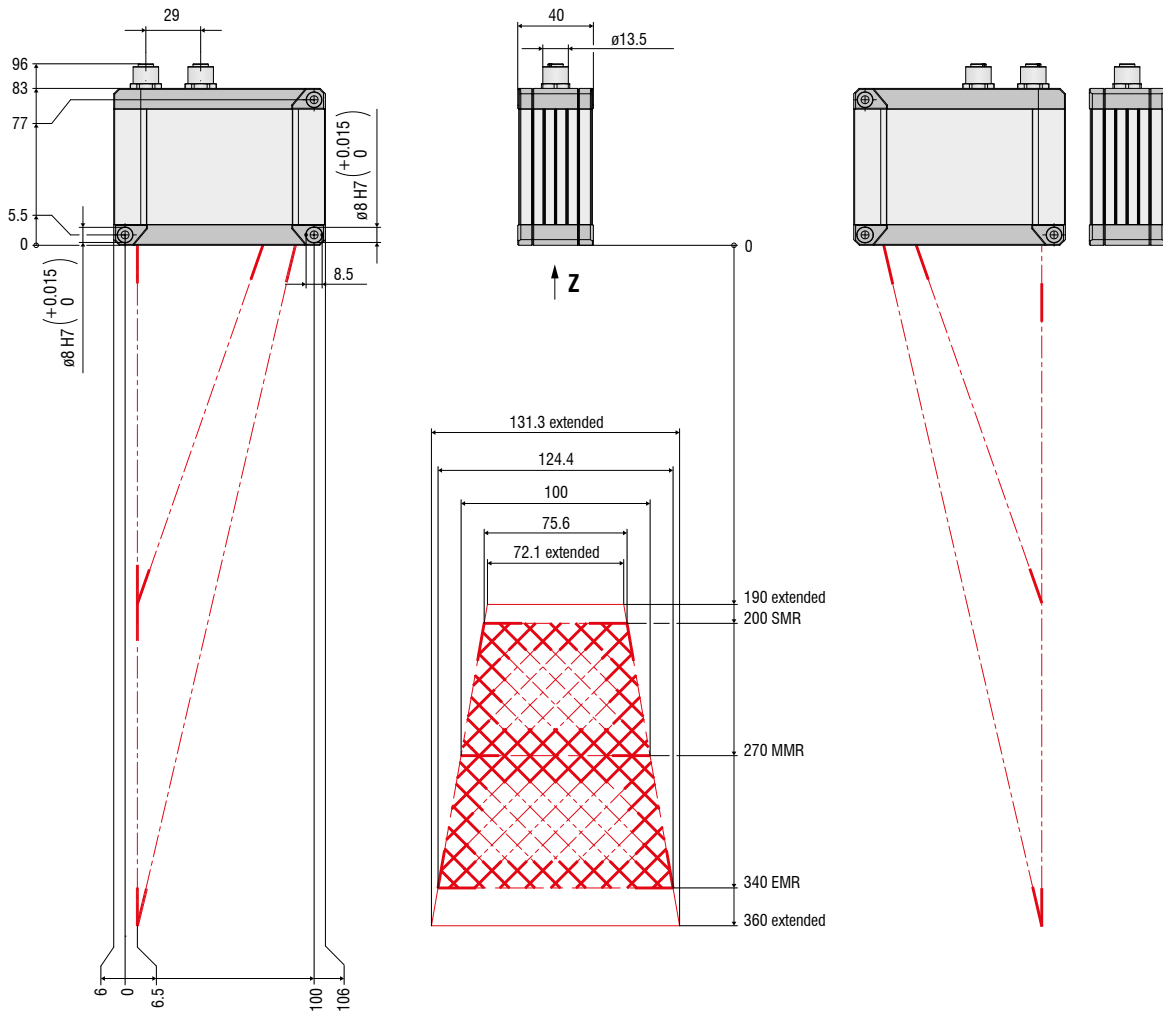

LLT30x2-200 / LLT30x0-200

Red Laser

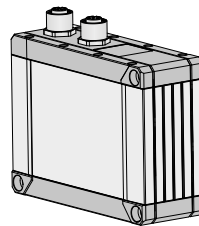
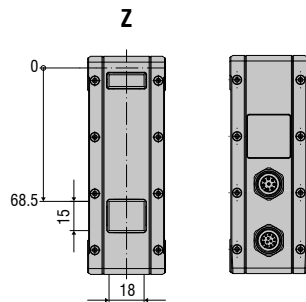
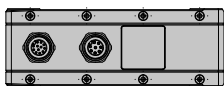
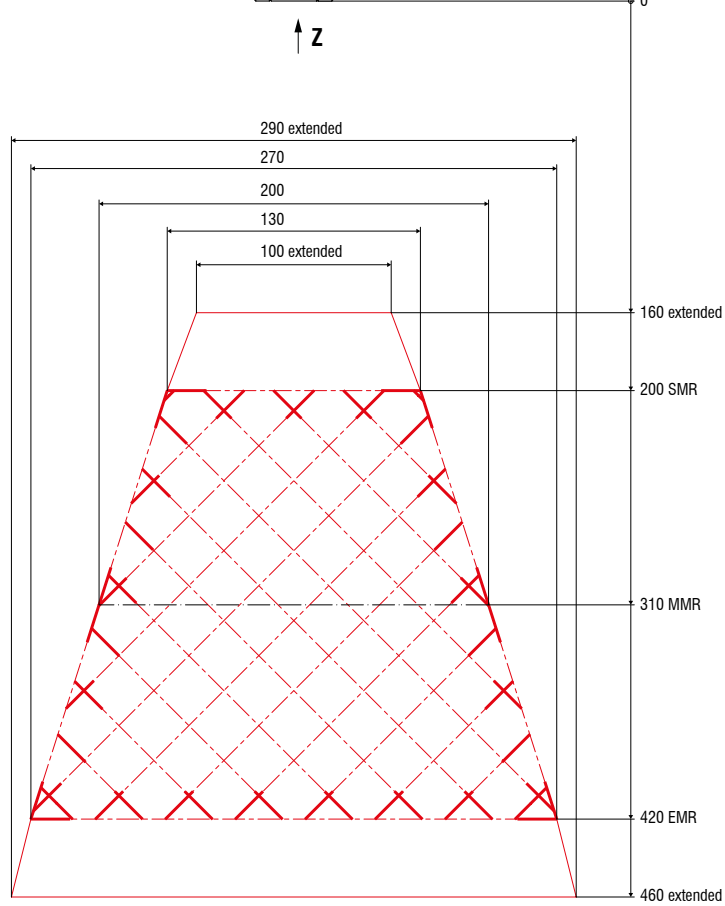
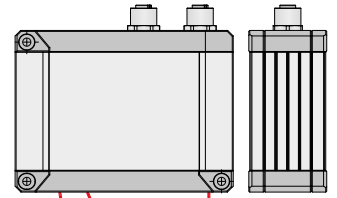
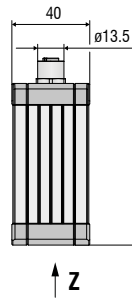
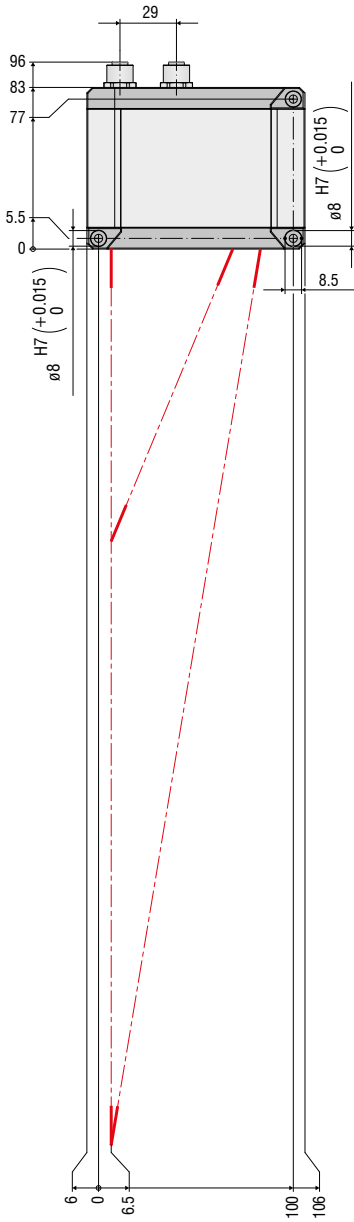

Dimensions and measuring ranges

scanCONTROL 30xx

LLT30x2-430 / LLT30x0-430

Red Laser

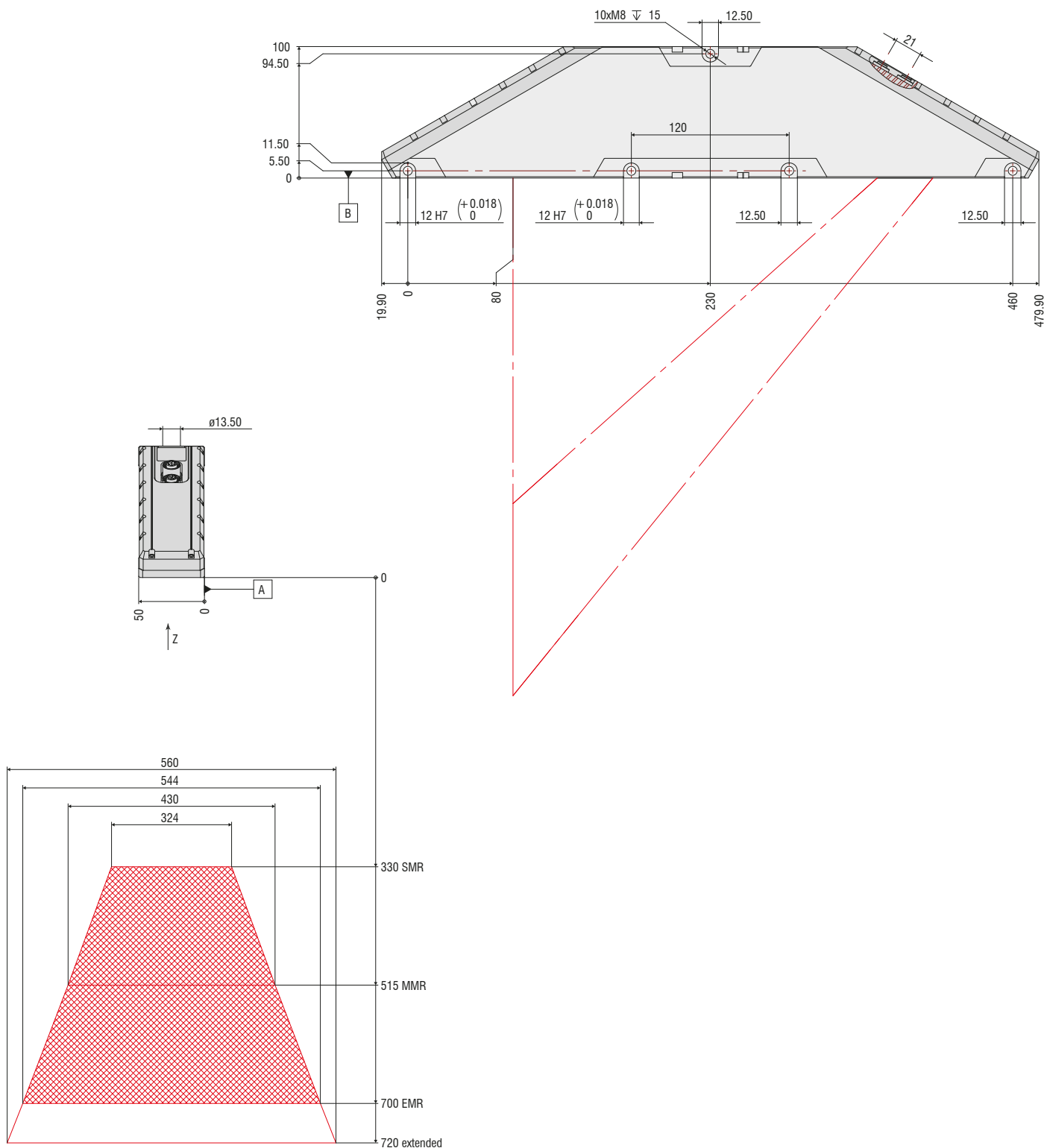

LLT30x2-600 / LLT30x0-600

Red Laser

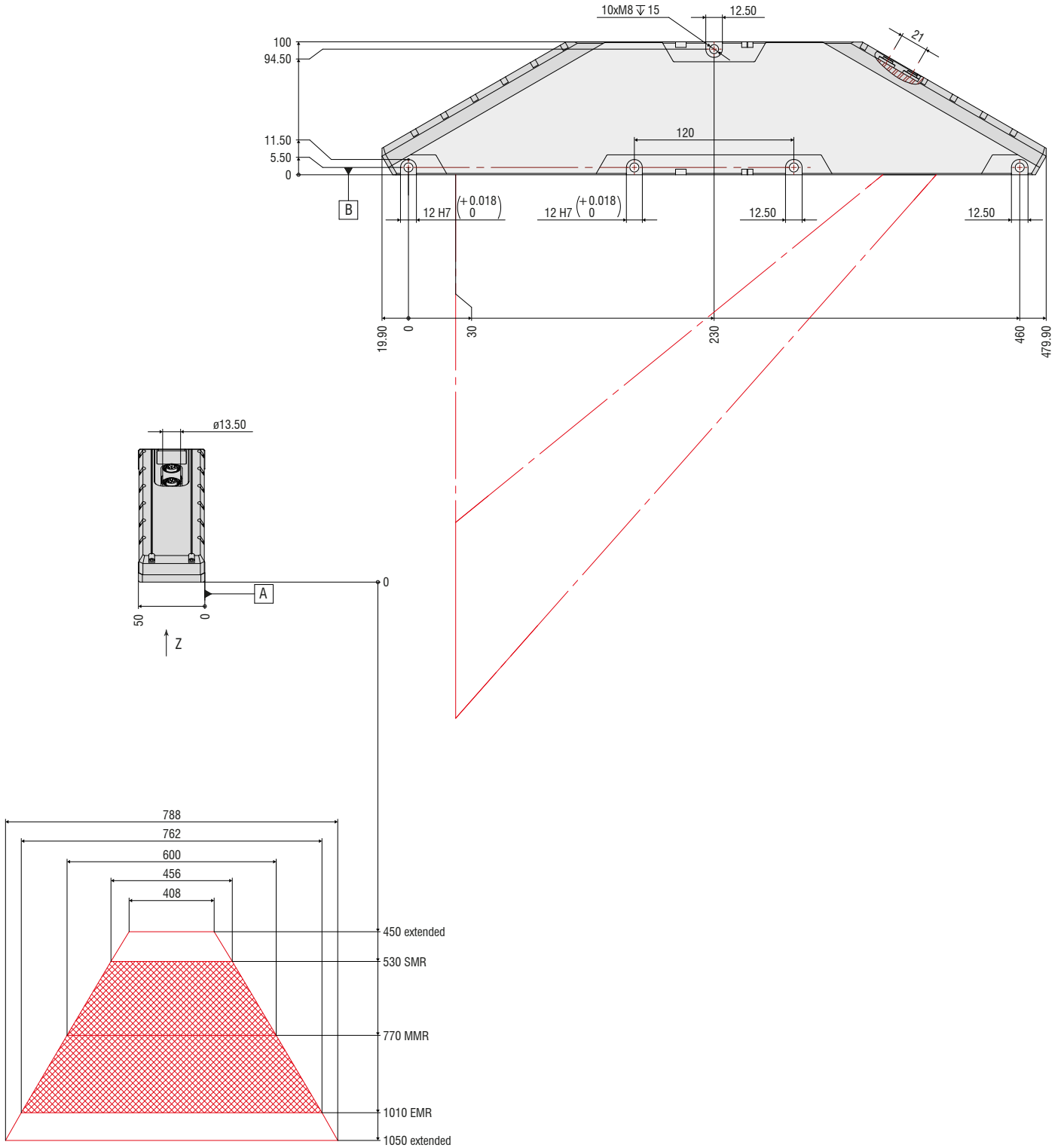

Software

scanCONTROL Configuration Tools

Plug & Play solution for complex measurement tasks

Evaluation directly in the sensor without external controller

Parallel execution of different measurement tasks and multiple evaluation

Easy online and offline analysis



scanCONTROL SMART sensors have an integrated intelligent controller for easy profile evaluation without requiring an additional PC. Configuration and parameter setup of the sensor is via the scanCONTROL Configuration Tools software. It enables sensor setup, viewing of profiles, as well as saving, loading and exporting profiles. All software functions can also be executed without a sensor in order to test the measurement task offline for very fast processes.

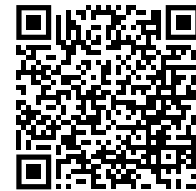

Download:
[micro-epsilon.com/
 2D_3D/laser-scanner/
 Software/downloads/](http://micro-epsilon.com/2D_3D/laser-scanner/Software/downloads/)

Easy 5-Step Configuration

1.

Alignment of the sensor



2.

Configuring the sensor

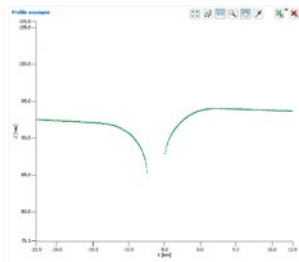

The software enables the user to completely configure the scanner in just five simple steps. After configuration, the scanner is in standalone mode and transmits the measured values to a PLC.

3.

Selection of measurement programs

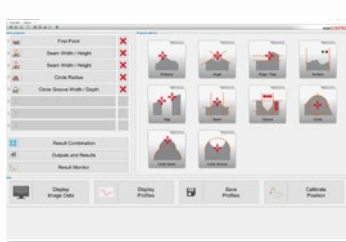

4.

Configuring the measurement programs

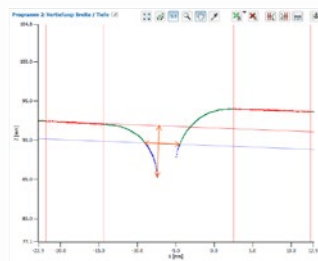

5.

Output and display of measured values



Numerous Setting Options

- 16 measuring programs + 8 evaluations per parameter set
- 15 independent parameter packages can be stored in the sensor
- Unlimited memory for parameter sets on the computer

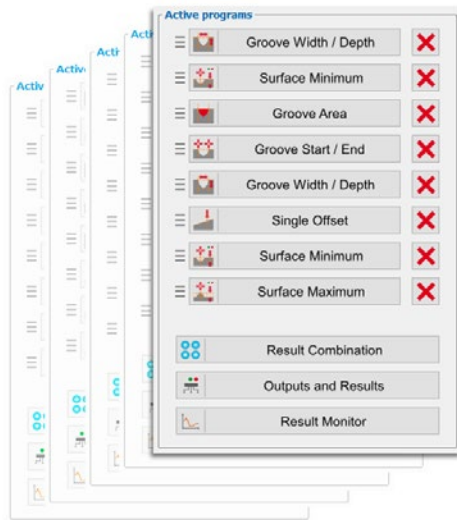

Wide Range of Measurement Tools

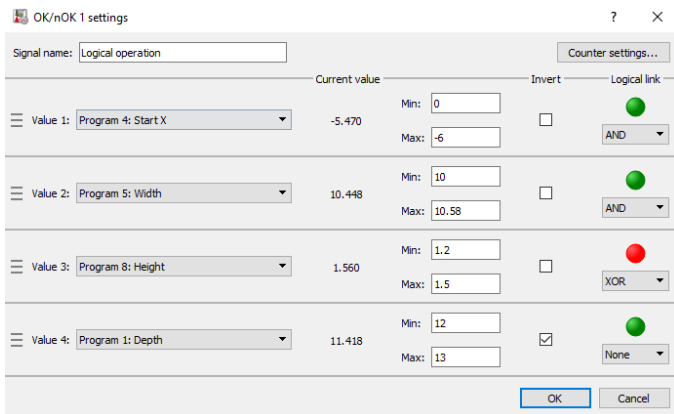
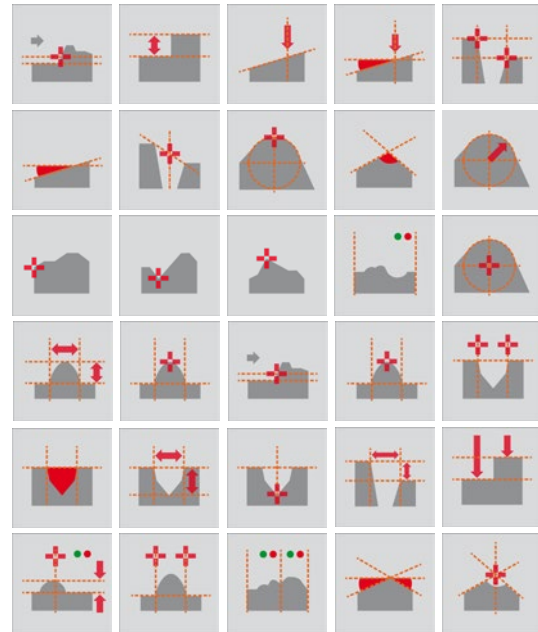

Logical Links

- Combined query of different conditions
- Summarized result evaluation in the sensor as OK/NOK

scanCONTROL Result Monitor

Result Monitor is a new software tool for displaying measured values of up to 4 SMART sensors.

- Display of profile and measured value history
- Different views, e.g., for workers
- Parallel transmission of the measured values to the control unit is possible and recommended
- Ring buffer logging and memory
- Adjustable layout



Software 3DInspect

Intuitive user interface

Real 3D evaluation, not just 2.5D

Object extraction in 3D

Direct feedback with algorithms

Compatible with all 3D sensors
from Micro-Epsilon

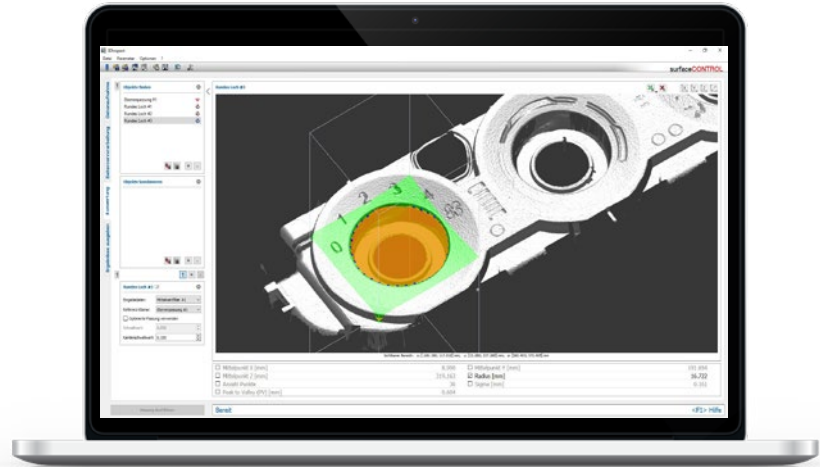

3DInspect software for 3D measurement and inspection tasks

The 3DInspect software is a powerful tool for sensor parameter set up and industrial measurement tasks. This software transmits the measurement data from the sensor via Ethernet and provides the data in three-dimensional form. This 3D data is further processed, evaluated and assessed with 3DInspect measuring programs on the PC and, if necessary, logged and transmitted via Ethernet to a control unit. Furthermore, the software enables the storage of 3D data. In addition to the scanCONTROL 30xx models, the 3DInspect software is also supported by the 3D Profile Unit as well as the surfaceCONTROL and reflectCONTROL sensors.

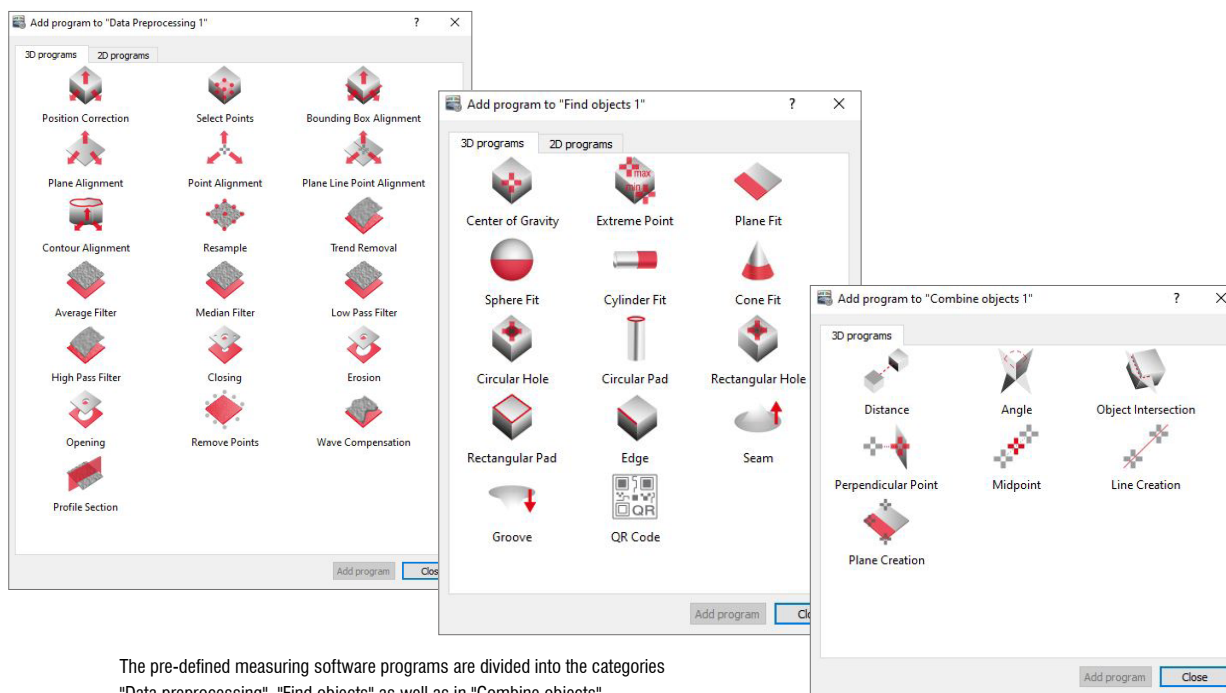



**Industrial Performance Unit:
Industrial PC with GigE Vision Sensors**

The Industrial Performance Unit is a powerful computing platform for 3D applications. The scanner can be parameterized directly via the 3DInspect software, allowing measurements to be started immediately. Results can be output via the integrated PROFINET, EtherCAT and EtherNet/IP interfaces.

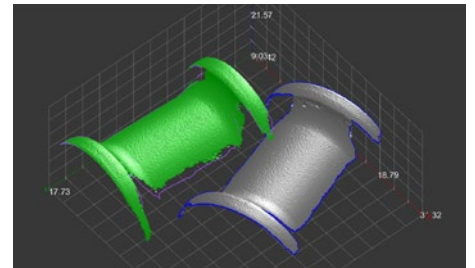
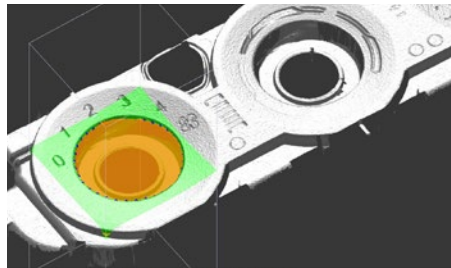
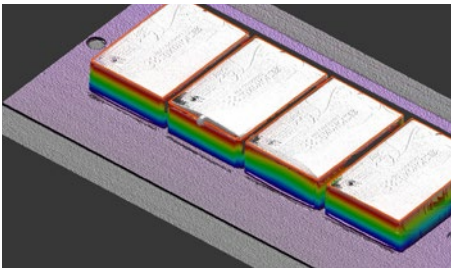
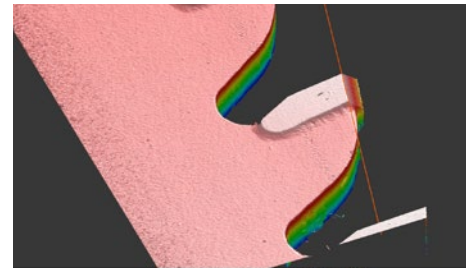
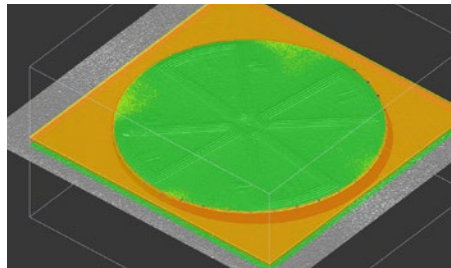
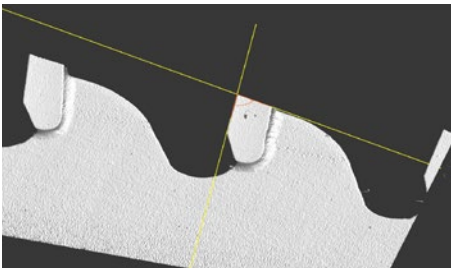
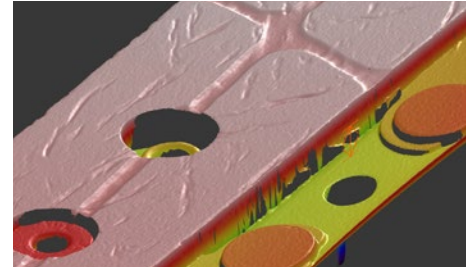
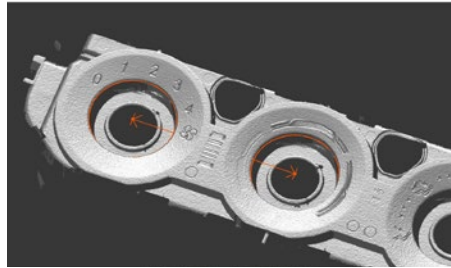
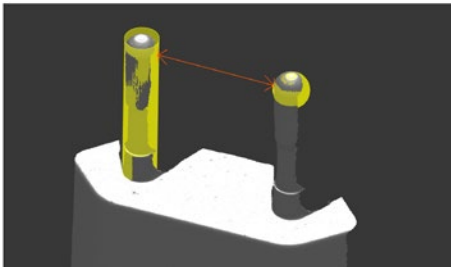

Valid3D technology from Micro-Epsilon vs. conventional 2.5D systems

The unique Valid3D technology enables lossless display and processing of the point clouds. This is how scanned 3D objects can be moved arbitrarily in the coordinate system.

Valid3D: Real 3D without data loss

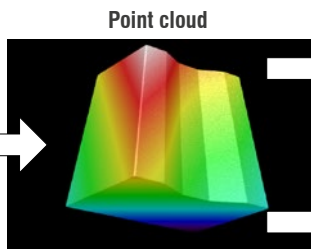
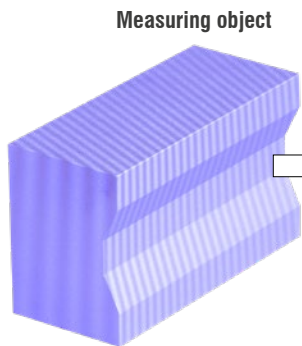

Point cloud after turn



- 3DInspect with Valid3D**
- Real 3D image of test object without data loss
 - Analysis and evaluation of complete test object

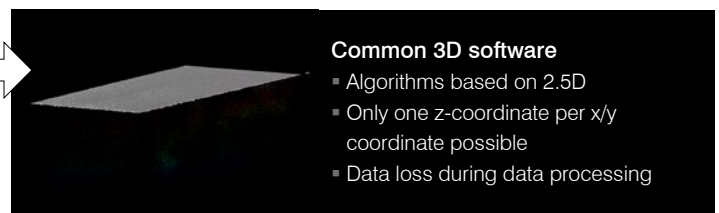

- Common 3D software**
- Algorithms based on 2.5D
 - Only one z-coordinate per x/y coordinate possible
 - Data loss during data processing

Integration of LLT sensors scanCONTROL



The scanCONTROL PROFILE sensors detect one profile from individual, calibrated points per measurement. Users can transfer these profiles to their own applications either individually or combined as an array/matrix in a container set. In addition to the data transfer of individual measuring points and their additional information (e.g. intensity, counter reading) the entire configuration of the sensor can also be controlled from its own application software. Micro-Epsilon provides a number of interfaces to access the parameter and data transfer functions. The transmission interface primarily used by scanCONTROL sensors for communications and profile transfer is Ethernet.

Ethernet and GigE Vision

Each scanCONTROL sensor complies with the GigE Vision Standard (Gigabit Ethernet for Machine Vision) of the AIA (Automated Imaging Association).

The standard is widely used in the image processing industry and is therefore supported by all conventional computer vision tools. This ensures fast and smooth integration into different image processing tools – also for 3D evaluation.

The GigE Vision standard stands for optimal data security, perfect performance and short implementation times. GigE Vision is based on Gigabit Ethernet and thus offers a high data transfer rate. Ethernet technology offers advantages such as long cable lengths without using repeaters/hubs, and it permits the use of inexpensive network components. The GigE Vision standard provides an open framework for data transmission (e.g. profiles, data sets) and control signals between the laser scanner and a PC. There are numerous infrastructure topology options for single- and multi-scanner applications.



Download:
[micro-epsilon.com/2D_3D/
laser-scanner/Software/
scanCONTROL-Integration/](http://micro-epsilon.com/2D_3D/laser-scanner/Software/scanCONTROL-Integration/)



Profile acquisition

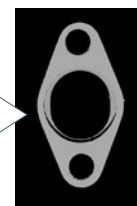

Grayscale image

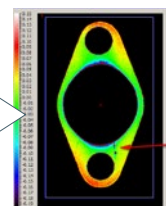

Image processing software

Integration with the C/C++ library

The C/C++ library for scanCONTROL supports both static and dynamic loading. Both stdcall and cdecl are supported as calling conventions. The individual functions of the library are clearly documented in the interface description and explained using examples.

The scanCONTROL SDK integration package includes:

- LLT.DLL library file
- Interfaces and scanCONTROL documentation
- Numerous programming examples for C++, Python, C# and Visual Basic (e.g. trigger, container mode)

The scanCONTROL Developer Tool demo program offers a complete integration example based on C++ for quick testing of the sensor configuration.

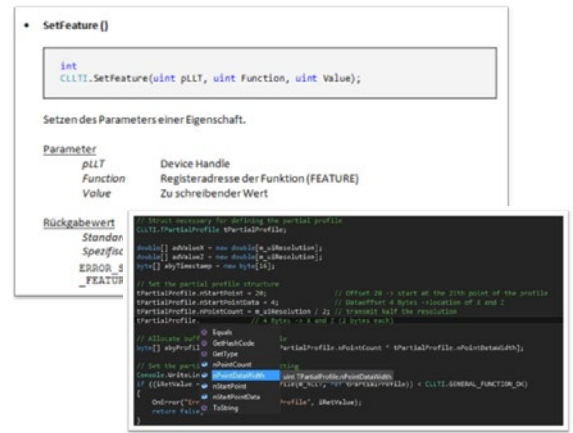

Integration with Linux

The integration into Linux is performed using an Open Source C library which has been extended with some important control features for scanCONTROL. An additional C++ library enables fast sensor integration of the entire functionality into a user-friendly API.

This library is based on the GeniCam standard which is why the sensor can be controlled via GeniCam commands or directly with the control parameters listed in the documentation. For integration support, some example programs are available (e.g. trigger, container mode). Use on ARM embedded PCs (e.g. Raspberry Pi) is possible with restrictions.

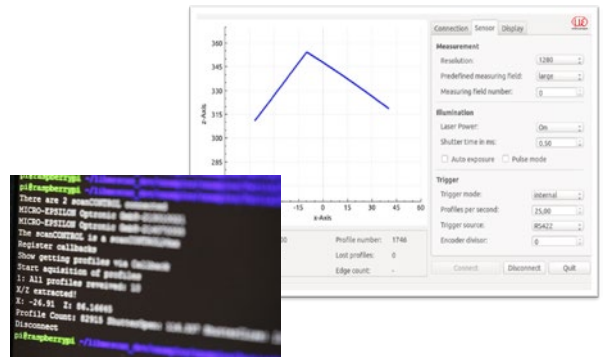

Integration with Cognex VisionPro

The scanCONTROL AIK adapter enables fast integration into Cognex VisionPro via the Cognex AIK Server. It combines the advantages of the Cognex VisionPro environment to generate fast and reliable measurement solutions with the advantages of native scanCONTROL integration.

Cognex Integrators and users of Cognex VisionPro can use the adapter to generate Cognex Range Images out of scanCONTROL's measurement points to process it comfortably with the VisionPro data evaluation algorithms for Range Images. Beyond that, all well-known configuration options for scanCONTROL sensors are available to the user.

To get a quick start, the scanCONTROL AIK adapter for Cognex VisionPro comprises an elaborate documentation on all sensor settings and the necessary configuration steps in Cognex VisionPro.

COGNEX® VisionPro

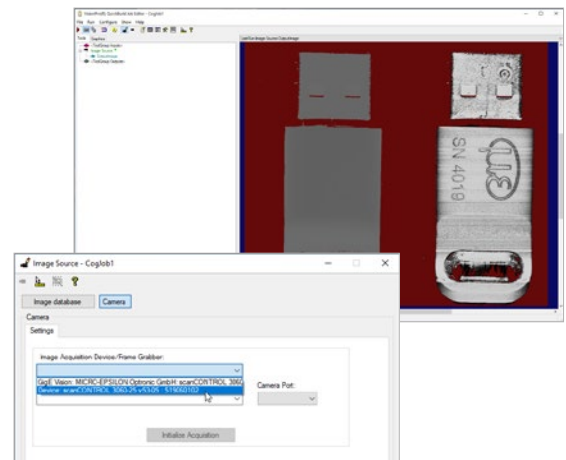

Integration with LabVIEW

The LabVIEW scanCONTROL instrument driver supports fast integration of scanCONTROL sensors into the LabVIEW application environment. For accessing a scanCONTROL sensor and its basic settings, users can drag-and-drop modules directly from the function palette into their VIs. Example VIs illustrating the scanCONTROL integration are also part of this package.

The integration of scanCONTROL sensors into the LabVIEW environment is based on the C/C++ library (LLT.DLL) of Micro-Epsilon. The documentation also shows how to set up additional special sensor parameters.

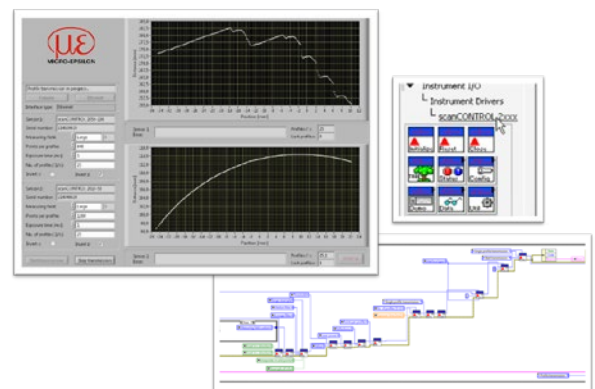

Profile stitching for up to 8 sensors 3D Profile Unit

NEW

Profile stitching for up to 8 laser scanners

Integration in GigE Vision as raw data provider

Industrial Ethernet connection for control
and transmission of measured values

Evaluation of composite 2D sections or 3D
point clouds

Compatible with scanCONTROL 30xx

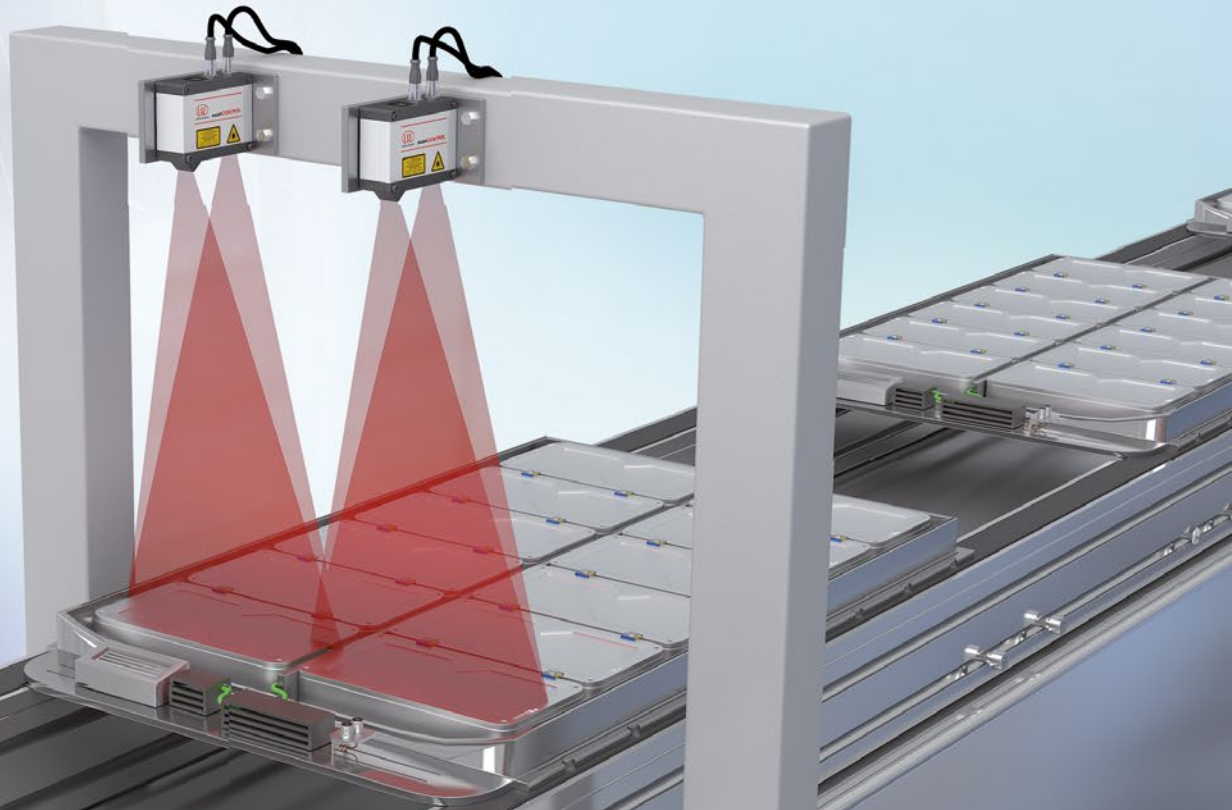
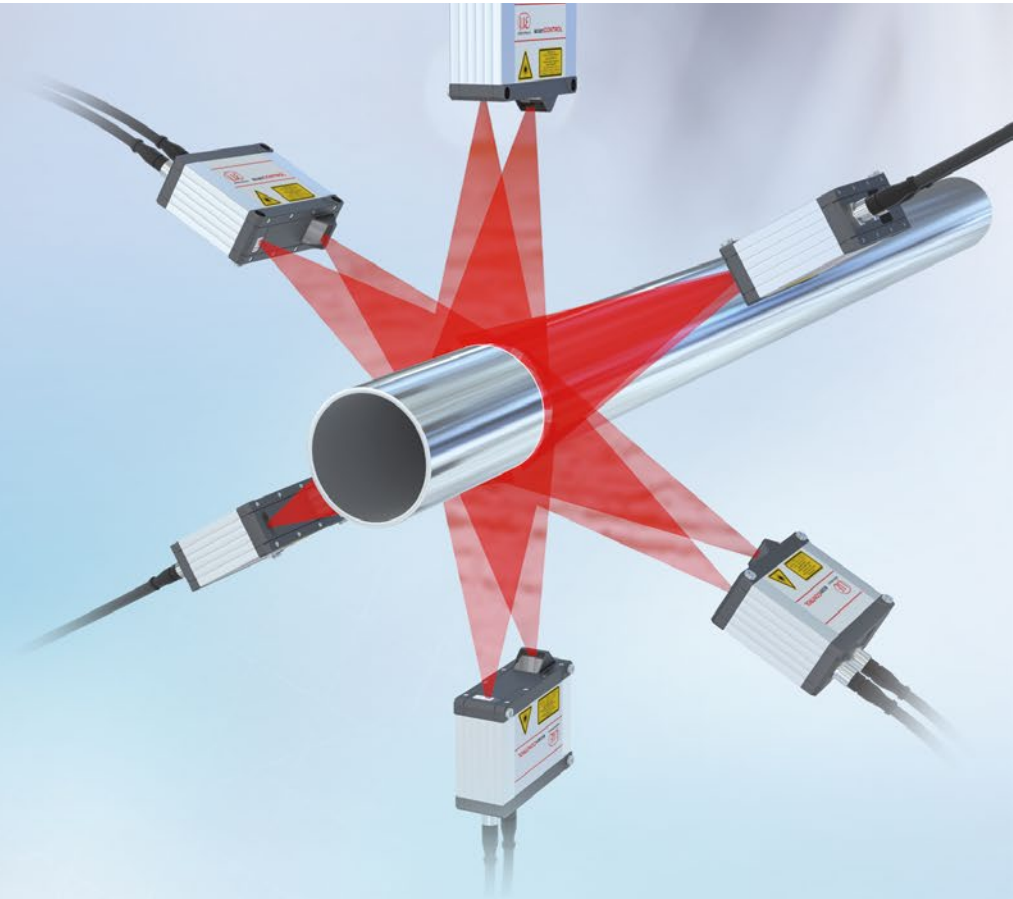

The 3D Profile Unit enables the calculation of several individual profiles of scanCONTROL 30xx sensors in a common coordinate system. This is how a composite 2D profile or a composite 3D point cloud can be generated. This enables the detection of various geometries, the extension of measuring ranges and the performance of thickness measurements.

The evaluation of the data and the parameterization of the system can be implemented in the 3DInspect software. The 3D-Profile-Unit controller offers an optional integrated evaluation feature in conjunction with the Industrial Ethernet connection, enabling the application to be controlled and measured values to be output to a PLC.

Alternatively, the 3D-Profile-Unit controller can also be integrated into common image processing programs via GigE Vision and acts as a raw data provider.

3D-Profile-Unit Controller

- Communication with any GigE Vision clients
- Direct integration into image processing software
- Transfer of profile data or 3D point clouds

3D-Profile-Unit Controller with Industrial Ethernet

- Integrated evaluation
- Transmission of measured values
- Industrial Ethernet interface for control and transmission of measured values



Application examples:



Volume measurement of food

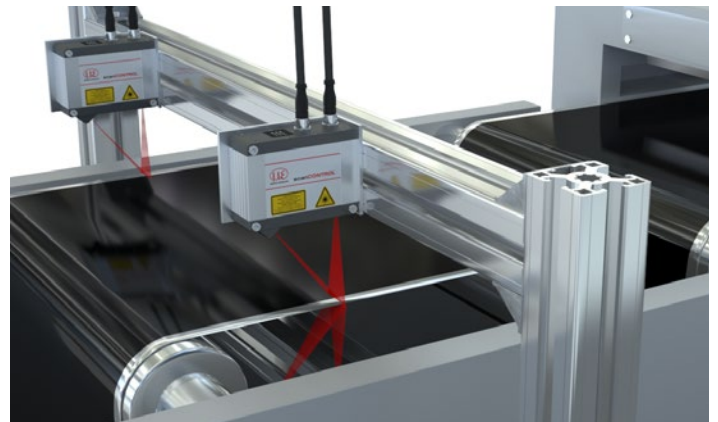

Width, thickness and Heavy Edge of battery film



Thickness of smartphone carrier plates

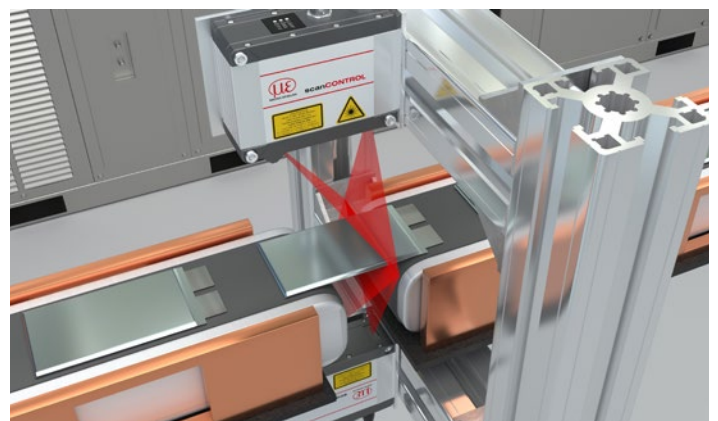

Inspection of pouch cells

Accessories

scanCONTROL

2D/3D Gateway

PROFINET / EtherCAT / EtherNet/IP for all SMART scanners

One 2D/3D Gateway is connectable with up to 4 sensors. Operation of more than one sensor requires a switch. The 2D/3D Gateway communicates with the scanCONTROL SMART sensor via Ethernet Modbus. The resultant values are then converted to PROFINET, EtherCAT or EtherNet/IP. The customer carries out the parameter setup with a detailed instruction manual. The gateway can also be parameterized in advance at the factory.

Models

6414142	2D/3D Gateway	Fieldbus coupler, configurable for PROFINET, EtherNet/IP and EtherCAT
6414142.001	2D/3D Gateway, pre-parameterized	Pre-parameterized to customer log and IP addresses

Number of sensors on the gateway	Maximum measurement frequency
1	500 Hz
2	500 Hz
3	330 Hz
4	250 Hz

NEW

Higher measurement frequencies are also possible with the 30xx sensors due to the Modbus bundling option.

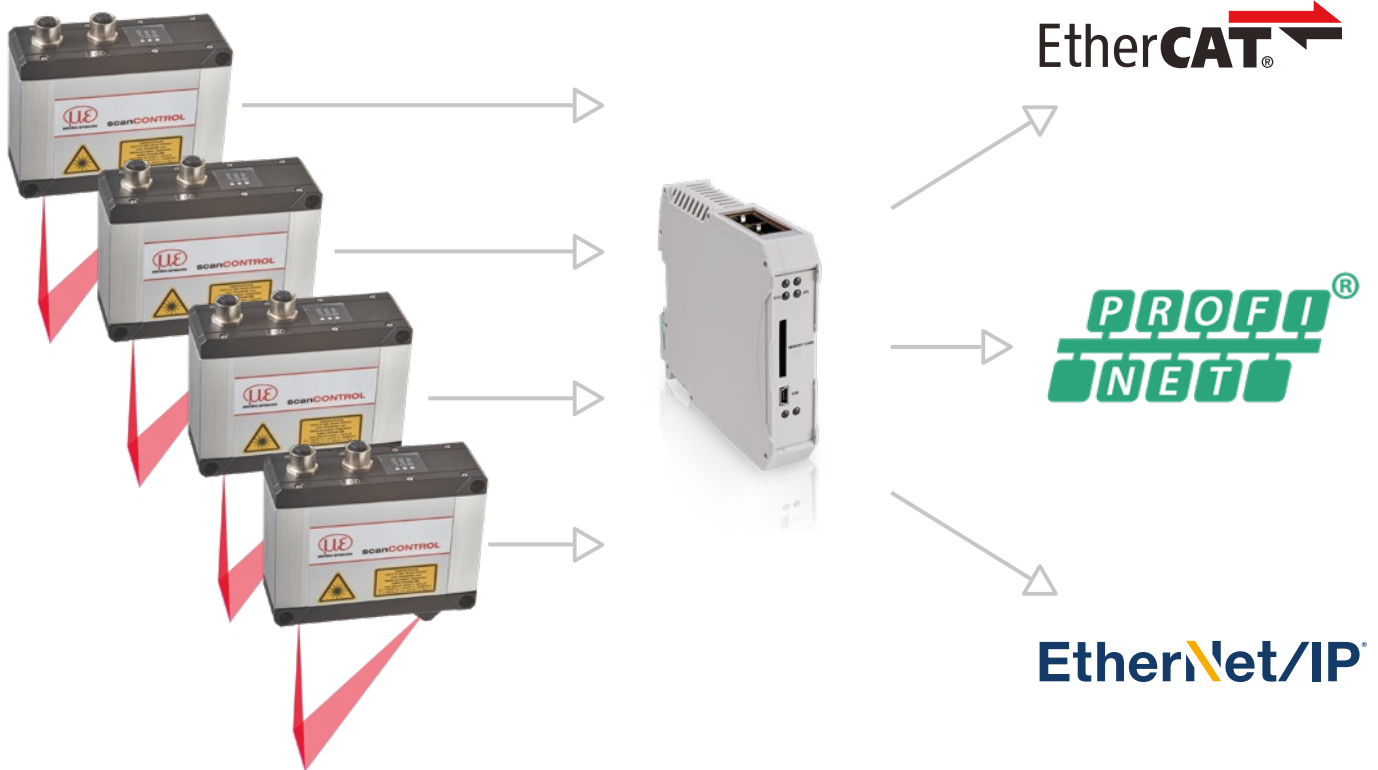

2D/3D Output Unit

Analog signals / digital switch signals for all **SMART** scanners

The 2D/3D Output Unit is addressed via Ethernet and outputs analog and digital signals. Different output terminals can be connected to the fieldbus coupler.

Models

6414073	2D/3D Output Unit Basic/ET	Fieldbus coupler with filter module and bus end terminal
0325131	OU-DigitalOut/8-channel/DC24V/0.5A/negative	8-channel digital output terminal; DC 24 V; 0.5 A; negative switching
0325115	OU-DigitalOut/8-channel/DC24V/0.5A/positive	8-channel digital output terminal; DC 24 V; 0.5 A; positive switching
0325116	OU-AnalogOut/4-channel/ ± 10 V	4-channel analog output terminal; ± 10 V
0325135	OU-AnalogOut/4-channel/0-10 V	4-channel analog output terminal; 0-10 V
0325132	OU-AnalogOut/4-channel/0-20 mA	4-channel analog output terminal; 0-20 mA
0325133	OU-AnalogOut/4-channel/4-20 mA	4-channel analog output terminal; 4-20 mA

Other terminals available on request.

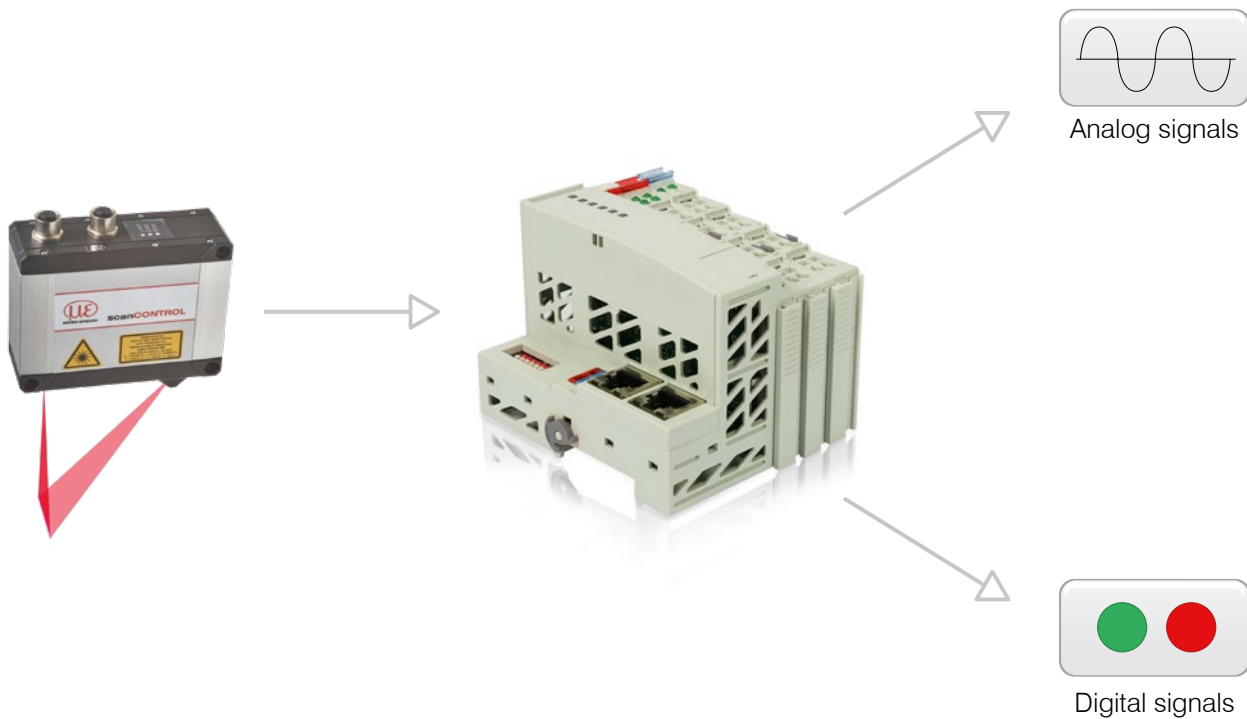

Accessories

scanCONTROL

Protection and cooling housing for LLT25x0 and 29xx

(Not available for scanCONTROL 29xx-10/BL)

Protective housing with blow-out system

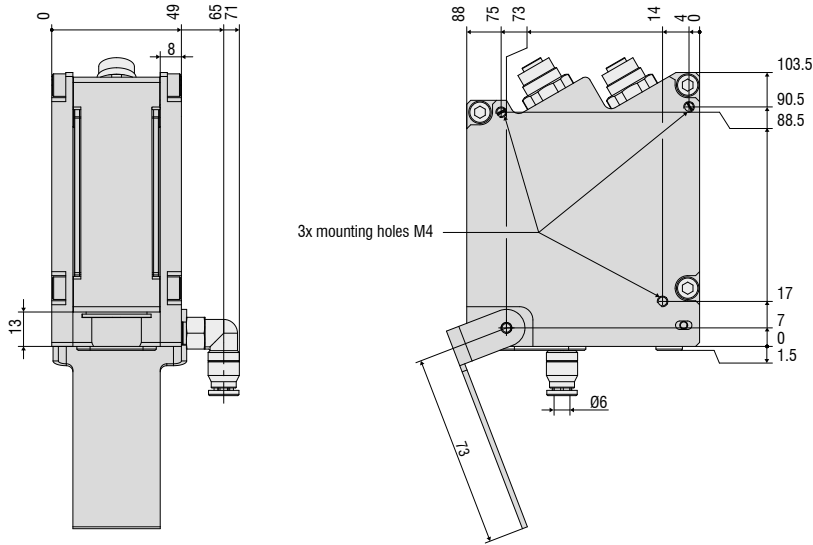

Protective housing with blow-out system and water cooling

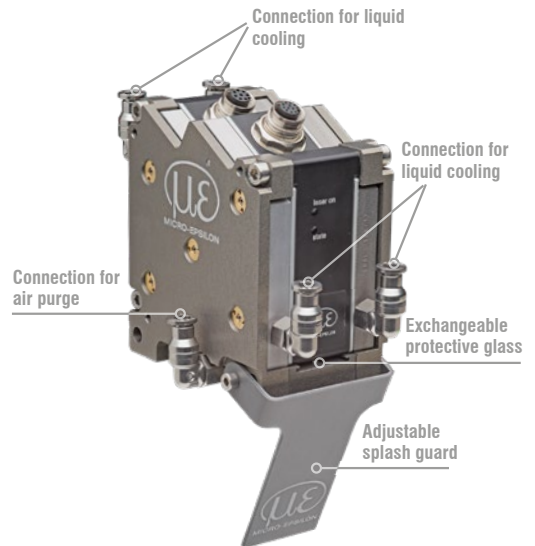
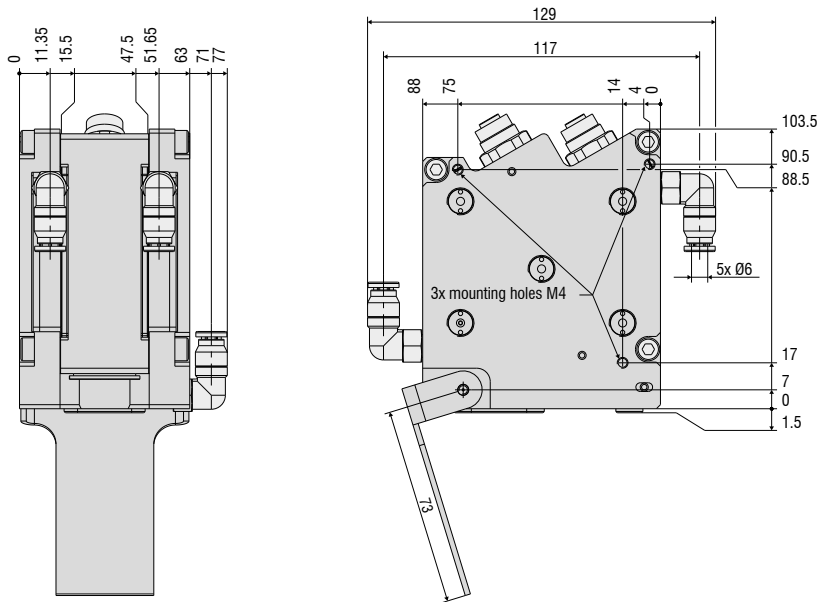

Art. no. Model

- 2105058 Protective housing for LLT25/29 series
- 2105059 Protective cooling housing for LLT25/29 series
- 0755075 Exchangeable glass for protective housing LLT25/29

Description

- Adaptive protective housing for LLT25x0/29xx
- Adaptive protection and cooling housing for LLT25x0/29xx
- Exchangeable glass for protection/cooling concept LLT25/29, packaging unit with 50 pcs.

Protection and cooling housing for LLT30xx

for the measuring ranges 25 - 200 mm

Protective housing with blow-out system

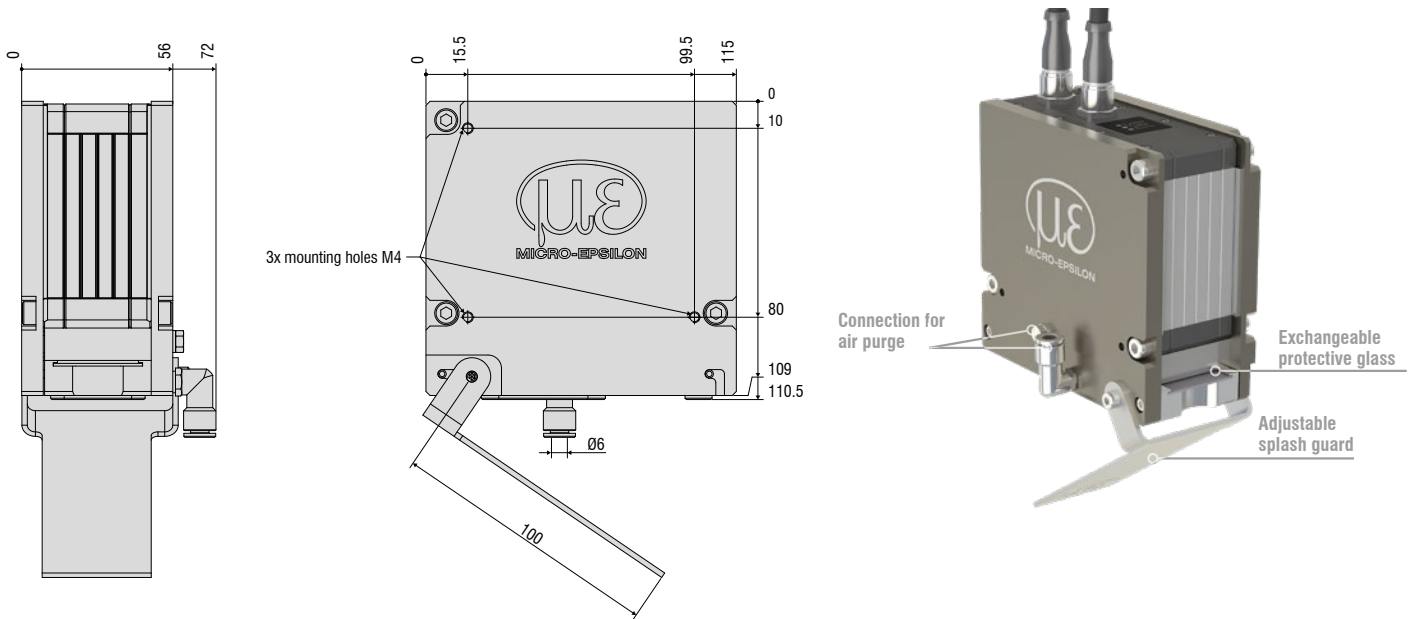

Protective housing with blow-out system and water cooling

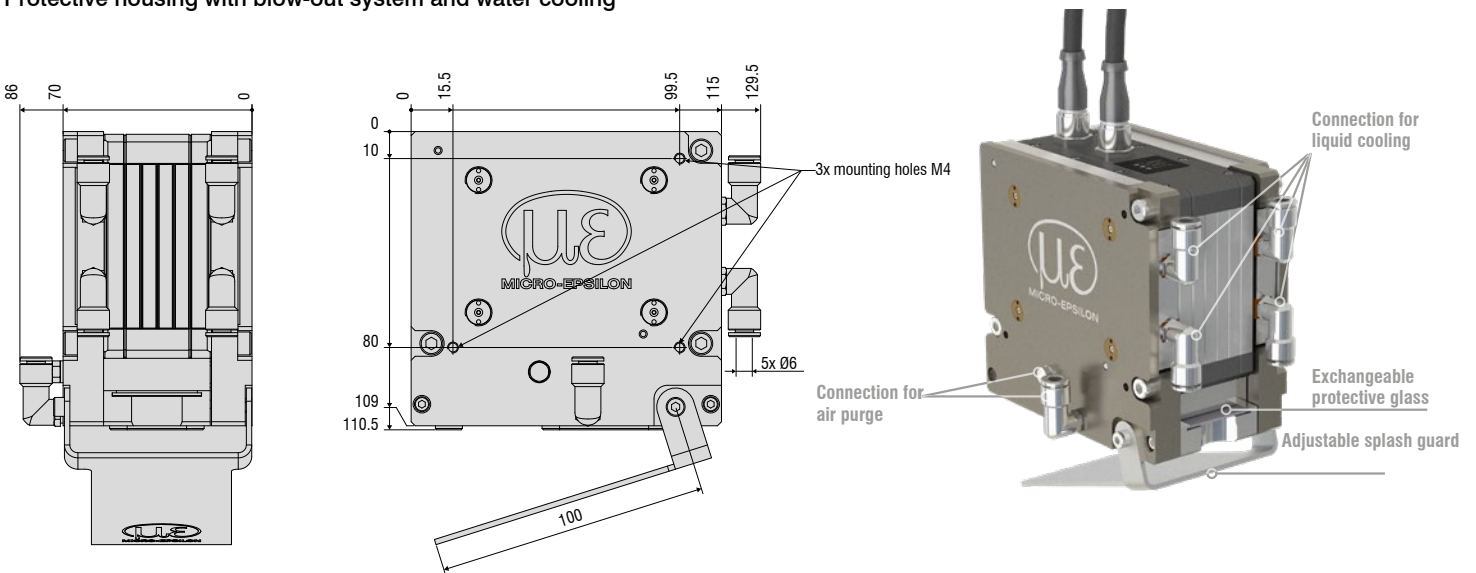

Art. no. Model

- 2105076 Protective housing for LLT30 series
- 2105077 Protective housing for LLT30 series
- 0755083 Exchangeable glass for protective housing LLT30

Description

- Adaptive protective housing for LLT30xx
- Adaptive protection and cooling housing for LLT30xx
- Exchangeable glass for protection/cooling concept LLT30, packaging unit with 30 pcs.

Accessories

scanCONTROL

Connection cables

PCR3000-x Multi-function cable

Cable for power supply, digital inputs (TTL or HTL), RS422 (half-duplex); suitable for drag chains and robots
Cable length (m): 2 / 5 / 10 / 15 / 20 / 25 / 35

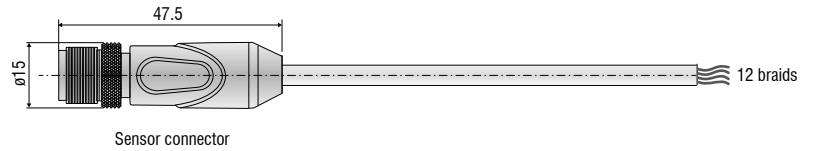

SCR3000A-x Ethernet connection cable

Cable for parameter setting, value and profile transmission; suitable for drag chains and robots
Cable length (m): 0.5 / 2 / 5 / 10 / 15 / 20 / 25 / 35

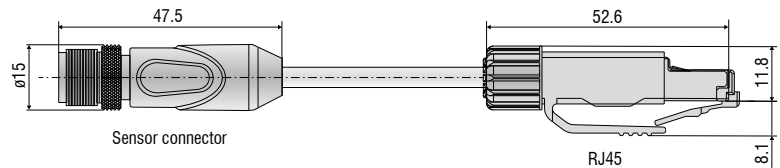

Other accessories

Art. no. Model

0323478 Connector/12-pin/Multifunction for LLT25/29/30 series
0323479 Connector/8-pin/Ethernet for LLT25/29/30 series
2420067 PS25/29/30
0254111 Case for LLT25/29/30 (up to MR 200)
0254153 Case for LLT30 series, MR 430/600
2960097 Measuring stand for LLT25/26/29/30 series
2960115 Measuring stand for LLT30 series, MR 430/600

Description

Plug for multifunction port
Plug for Ethernet socket
Power supply unit for scanCONTROL
Transport case for scanCONTROL sensors incl. measuring stand
Transport case for scanCONTROL sensors incl. measuring stand
Measuring stand with sensor adapter board, flexible rod and clamp base
Measuring stand with sensor adapter board, flexible rod and clamp base

3D snapshot sensors for the inspection of shapes and surfaces

surfaceCONTROL 3D 3500

Innovative 3D snapshot sensor for inline inspection of geometry, shapes and surfaces

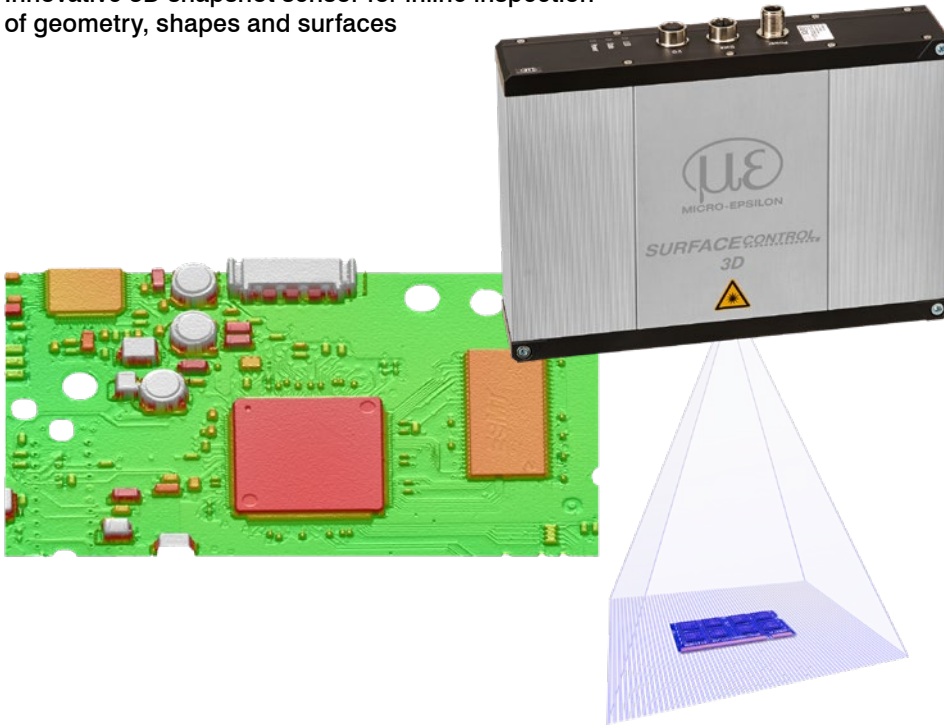

- Highest repeatability up to $0.25 \mu\text{m}$
- Best Z-axis resolution from $0.7 \mu\text{m}$
- Up to 2.2 million 3D points / second
- Easy integration in all common 3D image processing packets

reflectCONTROL

3D inline inspection of shiny surfaces: flat glass, mirrors and wafers

- Complete inspection of reflecting and shiny surfaces
- Highest z-accuracy $< 1 \mu\text{m}$
- Fastest 3D inspection $< 1 \text{ s}$
- High compatibility via different interfaces

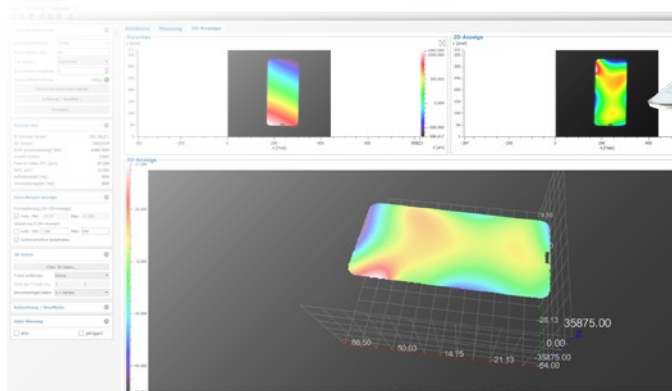
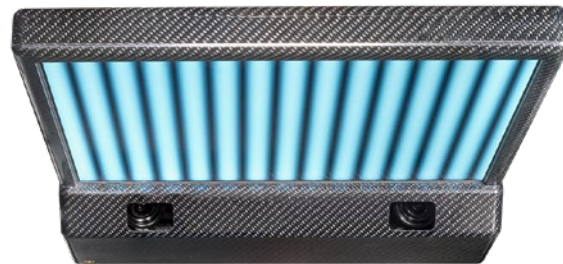

Sensors and Systems from Micro-Epsilon



Sensors and systems for displacement, distance and position



Sensors and measurement devices for non-contact temperature measurement



Measuring and inspection systems for metal strips, plastics and rubber

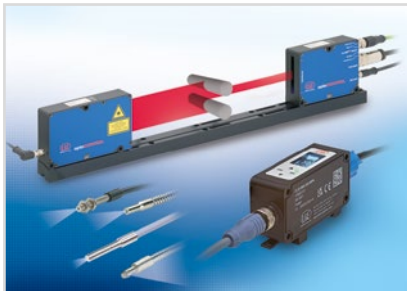

Optical micrometers and fiber optics, measuring and test amplifiers



Color recognition sensors, LED analyzers and inline color spectrometers



3D measurement technology for dimensional testing and surface inspection

